

SELECTRONIC® SENSOR-OPERATED URINAL FLUSH VALVE, 0.5 GPF BATTERY POWERED



GENERAL DESCRIPTION:

Exposed, sensor-operated Selectronic® Urinal Flush Valve for 3/4" top spud urinals. CR-P2 lithium battery powered.

PRODUCT FEATURES:

- **Factory-Installed CR-P2 Lithium Battery**
- **Pressure Compensation** feature ensures accurate flush volume regardless of inlet water pressure
- **Self-Cleaning Piston** with integral wiper spring significantly reduces clogging and maintenance
- **No Routine Maintenance** no diaphragms to replace; no filters to clean
- **Selectronic® Proximity System** with universal sensor provides hygienic, "hands free" operation
- **State-of-the-Art Electronics** prevent ghost flushing
- **Dezincification Resistant** semi-red brass alloy
- **Fully Mechanical Manual Override Button** can flush the valve without power
- **Fail-Safe:** Valve automatically closes upon loss of power or water pressure and does not need to be reset
- **Adjustable Sanitary Flush** cleans the fixture & maintains the trap seal.
- **Stadium Feature:** Valve automatically switches to water savings mode during periods of heavy usage
- **Chemical Resistant EPDM Seals** for extended life
- **High Back Pressure Vacuum Breaker**
- **Adjustable Tailpiece**
- **Range can be adjusted manually or with optional remote control**
- **No external volume adjustment.**
- **Can be installed left or right handed**

MODEL NUMBER:

- ❑ **6063.051.002** Exposed, sensor-operated flush valve for 3/4" top spud urinals, 0.5 gpf.
Inlet includes 3/4" sweat solder kit and angle stop with back flow protection and vandal-resistant cap.
Outlet includes 3/4" high back pressure vacuum breaker with spud coupling and flange.
- ❑ **6063.505.002** Retrofit Valve Only, 0.5 gpf

OPERATING PRESSURE:

20 psi (flowing) - 80 psi (static)

FLOW REQUIREMENT:

10 gpm (37.9 L/min.)

BATTERY LIFE:

4 years @ 4,000 flushes per month

OPTIONAL ACCESSORY:

- Cast wall flange with set screw (6065816.002)
- 12-1/2" long vacuum breaker (M964446-0020A)
- 4" longer than standard

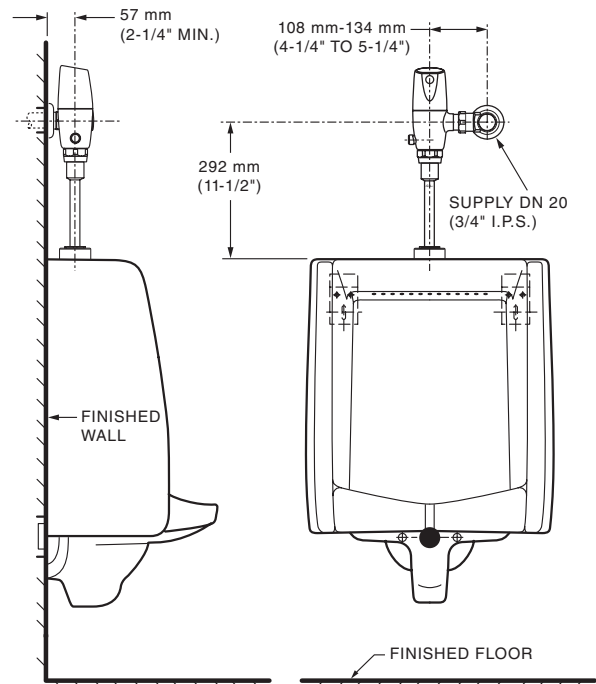

RECOMMENDED SPECIFICATION:

Electronic, sensor activated urinal flush valve shall feature self-cleaning piston valve with integral wiper spring in refill orifice to prevent clogging. Includes a factory-installed CR-P2 lithium battery and fully mechanical manual override that can flush the valve without power. Includes semi-red brass valve body and metal cover with chrome finish. Includes angle stop with back-flow protection & vandal-resistant cap. Sweat solder kit and high back pressure vacuum breaker also included. 0.5 gpf / 1.9 Lpf flush valve shall be American Standard Model # 6063.051.002.

LISTINGS:

- ASSE 1037
- ANSI/ASME A112.19.2
- ADA Compliant

Roughing-in Dimensions

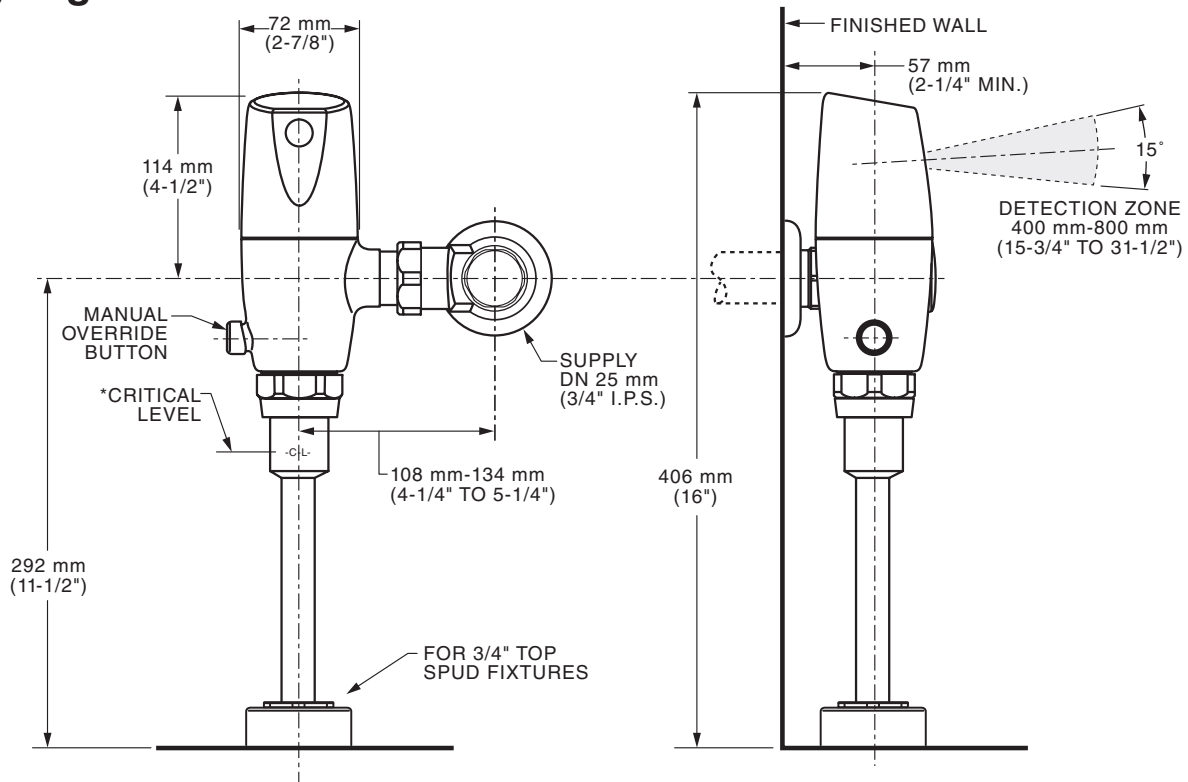

*Note: The Critical Line (-C-L-) on Vacuum Breaker must typically be 6" (152mm) above fixture. Consult Codes for details.

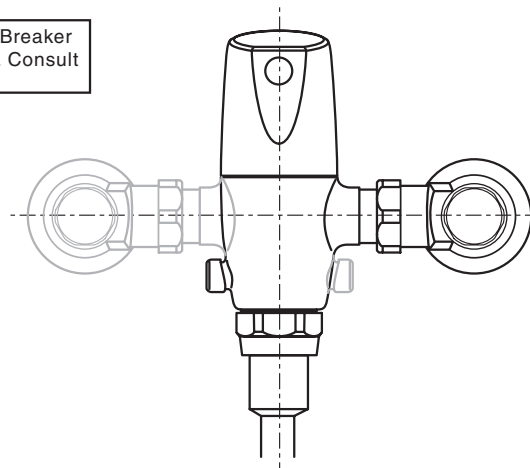

Right or Left Hand Installation