

CARBON STEEL 3-PIECE FULL PORT BALL VALVE W/ ACTUATOR READY ISO MOUNTING PAD 1.5" & 2"

Full Port Threaded, 800 CWP (psig), Cold Non-Shock. 150 psig Saturated Steam.
 Vacuum Service to 29 inches Hg.
 MSS SP-110 compliant.
 Meets NACE MR0175 (2000) & MR0103 (2012)



FEATURES

- Multi-piece packing set
- ISO 5211 mounting pad
- Blowout-proof stem design
- In-line repairable
- Adjustable packing gland
- Investment cast components
- Reinforced seats and seals
- Full port configuration

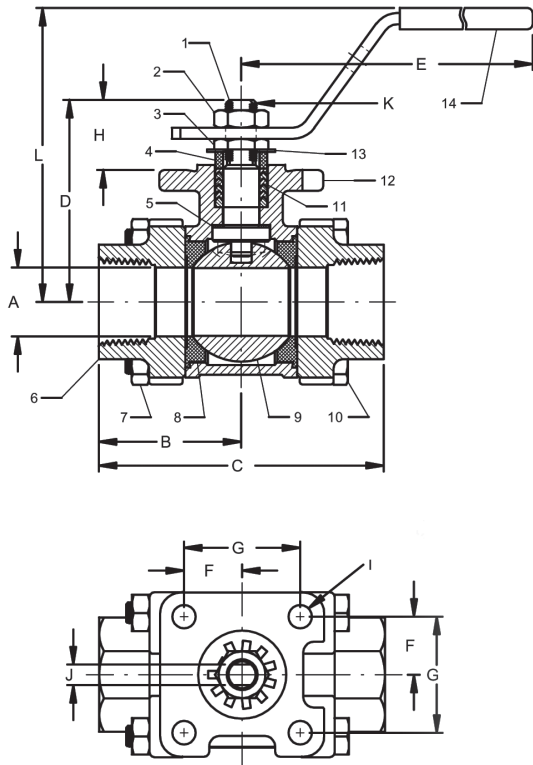

OPTIONS AVAILABLE: (MORE INFORMATION IN SECTION J)

- Minimum quantities apply
- To specify an option, replace the "01" standard suffix with the suffix of the option.
- To specify multiple options, replace the "01" suffix with the desired suffixes in the numerical order shown below. NOTE: Not all suffixes can be combined together.

(SUFFIX)	OPTION
-01	Standard Configuration
-P -01-	BSPP (Parallel) Thread Connection
-T -01-	BSPT (Tapered) Thread Connection
-02-	Static Grounded
-04-	2.25" Stem Extension (Carbon Steel, Zinc Plated)
-08-	90° Reversed Stem
-10-	SS Lever & Nut
-14-	Vented Ball
-18-	Plain Yellow Grip
-21-	UHMWPE Seats (Non-PTFE)
-24-	Graphite packing
-27-	Latch Lock Lever
-35-	PTFE Trim
-36-	SS Round Handle
-39-	SS Hi-Rise Locking Wheel Handle, SS Nut
-49-	No Lubrication. Assembled Dry.
-56-	Multifill Seats & Graphite Packing
-59-	SS External Trim - 3-pc. Valves
-60-	Grounded Ball & Stem
-63-	NPT x Socket Weld
-66-	NPT x Buttweld
-67-	Cleaned For Industrial Gases
-AR-	Less Handle & Stop-Add Belleville Washers
-WB-	With Lever & Belleville Washers

STANDARD MATERIAL LIST

PART	MATERIAL
1 Stem	A276-316
2 Jam nut	Steel, zinc plate
3 Low profile nut	316 SS
4 Gland	A276-316
5 Stem bearing	RPTFE
6 End cap (2)	A216-WCB
7 Hex nut (4)	Stl-gr. 8-zinc plt
8 Seat (2)	RPTFE
9 Ball	316 SS
10 Body bolt (4)	Stl-gr. 8-zinc plt
11 Stem packing	MPTFE
12 Body	ASTM A216-WCB
13 Lock tab washer	304 SS
14 Lever and grip	Stl-zinc plt-w/vinyl

DIMENSIONS

PRODUCT NUMBER	SIZE	A	B	C	D	E	F	G	H	I	J (FLATS)	K (THREADS) UNF	L
83R-147-01	1.5"	1.50	2.59	5.18	3.49	8.06	.98	1.95	1.16	0.34	.370/.372	5/8-18	4.35
83R-148-01	2"	2.00	3.01	6.03	3.95	8.06	.98	1.95	1.16	0.34	.370/.372	5/8-18	4.85

Pressure/Temperature Ratings - Page M-12, Graph No. 7



83R-140 SERIES

CARBON STEEL 3-PIECE FULL PORT BALL VALVE W/ ACTUATOR READY ISO MOUNTING PAD 3"

Full Port Threaded, 800 CWP (psig), Cold Non-Shock. 150 psig Saturated Steam.
 Vacuum Service to 29 inches Hg.
 MSS SP-110 compliant.
 Meets NACE MR0175 (2000) & MR0103 (2012)



FEATURES

- Multi-piece packing set
- ISO 5211 mounting pad
- Blowout-proof stem design

- In-line repairable
- Adjustable packing gland
- Investment cast components
- Reinforced seats and seals
- Full port configuration

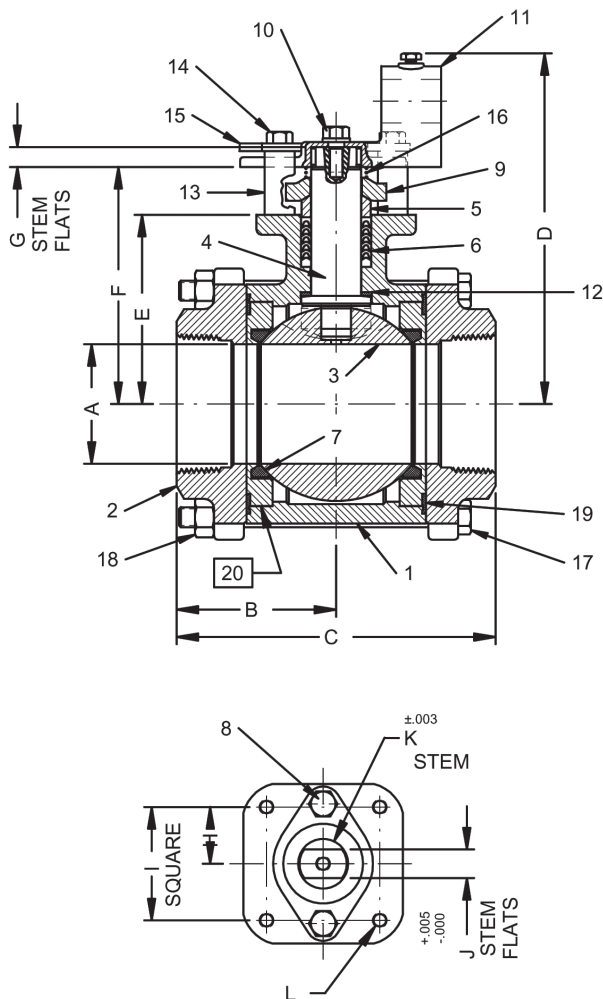

OPTIONS AVAILABLE: (MORE INFORMATION IN SECTION J)

- Minimum quantities apply
- To specify an option, replace the "01" standard suffix with the suffix of the option.
- To specify multiple options, replace the "01" suffix with the desired suffixes in the numerical order shown below. NOTE: Not all suffixes can be combined together.

(SUFFIX)	OPTION	SIZES
-01	Standard Configuration	All
-02-	Static Grounded	3"
-14-	Vented Ball	3"
-24-	Graphite packing	3"
-35-	PTFE Trim	3"
-49-	No Lubrication. Assembled Dry.	3"
-60-	Grounded Ball & Stem	3"
-63-	NPT x Socket Weld	3"
-67-	Cleaned For Industrial Gases	3"
-70-	4" Extended Bonnet	3"

Pressure/Temperature Ratings - Page M-12, Graph No. 7

STANDARD MATERIAL LIST

	PART	MATERIAL
1	Body	ASTM A216-WCB
2	End Caps	ASTM A216-WCB
3	Ball	316 SS
4	Stem	A276-316
5	Packing Gland	Carbon Steel
6	Stem Seal	MPTFE
7	Seats (2)	RPTFE
8	Gland Screws (2)	Stainless Steel
9	Gland Plate	Stainless Steel
10	Adapter Screw	Stainless Steel
11	Handle Adapter	Stainless Steel
12	Stem Bearing	RPTFE
13	Stops (2)	Stainless Steel
14	Stop Screws (2)	Stainless Steel
15	Lock Plate	Stainless Steel
16	Grounding Spring	Stainless Steel
17	Body Bolts (6)	Stainless Steel
18	Heavy Hex Nuts (6)	Stainless Steel
19	Body Seals (2)	RPTFE
20	Seat Holders (2)	Carbon Steel
21	Pipe Handle	(not shown)

DIMENSIONS

PRODUCT NUMBER	SIZE	A	B	C	D	E	F	G	H	I	J (FLATS)	K	L (THREADS).UNF
83R-140-01	3"	3.00	4.00	8.00	8.80	4.75	5.94	0.50	1.420	2.840	0.725	1.250	3.28

The listed C_v “factors” are derived from actual flow testing, in the Apollo® Ball Valve Division, Conbraco Industries, Inc., Pageland, South Carolina. These tests were completed using standard “off the shelf” valves with no special preparation and utilizing standard schedule 40 pipe. It should be understood that these factors are for the valve only and also include the connection configuration. The flow testing is done utilizing water as a fluid media and is a direct statement of the gallons of water flowed per minute with a 1 psig pressure differential across the valve/connection unit. Line pressure is not a factor. Because the C_v is a factor, the formula can be used to estimate flow of most media for valve sizing.

FLOW OF LIQUID

$$Q = C_v \sqrt{\frac{\Delta P}{SpGr}}$$

$$\text{or } \Delta P = \frac{(Q)^2 (SpGr)}{(C_v)^2}$$

WHERE:

- Q = Flow in US gpm
- ΔP = Pressure drop (psig)
- SpGr = Specific gravity at flowing temperature
- C_v = Valve constant

FLOW OF GAS

$$Q = 1360 C_v \sqrt{\frac{(\Delta P) (P_2)}{(SpGr) (T)}}$$

$$\text{or } \Delta P = \frac{5.4 \times 10^{-7} (SpGr) (T) (Q)^2}{(C_v)^2 (P_2)}$$

WHERE:

- Q = Flow in SCFH
- ΔP = Pressure drop (psig)
- SpGr = Specific gravity (based on air = 1.0)
- P2 = Outlet pressure-psia (psig + 14.7)
- T = (temp. °F + 460)
- C_v = Valve constant

CAUTION: The gas equation shown, is valid at very low pressure drop ratios. The gas equation is NOT valid when the ratio of pressure drop (ΔP) to inlet pressure (P1) exceeds 0.02.

NOTE: Only use the gas equation shown if (P1-P2)/P1 is less than 0.02.

Cv FACTORS FOR APOLLO VALVES (continued on M-4)

VALVE	SIZE (IN.)														
	1/4	3/8	1/2	3/4	1	1.25	1.5	2	2.5	3	4	6	8	10	12
70B-140 Series	8.4	7.2	15	30	43	48	84	108	190	370	670	--	--	--	--
70-100/200 Series	8.4	7.2	15	30	43	48	84	108	190	370	670	--	--	--	--
70-300/400 Series	--	--	15	30	43	48	84	108	--	--	--	--	--	--	--
70-600 Series	2.3	4.5	5.4	12	14	21	34	47	--	--	--	--	--	--	--
70-800 Series	8.4	7.2	15	30	43	48	84	--	--	--	--	--	--	--	--
71-AR Series	--	--	--	30	43	48	84	108	190	370	--	--	--	--	--
71-100/200 Series	--	--	--	30	43	48	84	108	190	370	--	--	--	--	--
72-100/900 Series	--	--	26	48	65	125	170	216	--	--	--	--	--	--	--
72-1xx-A/72-9xx-A Series	--	--	26	48	65	125	170	245	--	--	--	--	--	--	--
73A-100 Series	8.4	7.2	15	30	43	48	84	108	--	--	--	--	--	--	--
73-300/400 Series	--	--	26	48	65	125	170	216	--	--	--	--	--	--	--
74-100 Series	8.4	7.2	15	30	43	48	84	108	190	370	670	--	--	--	--
75-100 Series	8.4	7.2	15	30	43	48	84	108	190	370	670	--	--	--	--
76-AR Series	8.4	7.2	15	30	43	48	84	108	190	370	670	--	--	--	--
76F-100 Series	8.1	15	15	51	68	125	177	389	--	--	--	--	--	--	--
76FJ-100 Series	8.1	15	15	51	68	125	177	389	--	--	--	--	--	--	--
76FK-100 Series	8.1	15	15	51	68	125	177	389	--	--	--	--	--	--	--
76-100 Series	8.4	7.2	15	30	43	48	84	108	190	370	--	--	--	--	--
76-300/400 Series	--	--	26	48	65	125	170	216	--	--	--	--	--	--	--
76-600 Series	2.3	4.5	5.4	12	14	21	34	47	--	--	--	--	--	--	--
76J-100 Series	8.4	7.2	15	30	43	48	84	108	190	370	--	--	--	--	--
76J-AR Series	8.4	7.2	15	30	43	48	84	108	190	370	670	--	--	--	--
76K-100 Series	8.4	7.2	15	30	43	48	84	108	190	370	--	--	--	--	--
76K-AR Series	8.4	7.2	15	30	43	48	84	108	190	370	670	--	--	--	--
7K-100 Series	--	--	15	51	68	125	177	389	503	--	--	--	--	--	--
77-AR Series	8.1	15	15	51	68	--	177	389	--	--	--	--	--	--	--

FLOW DATA FOR APOLLO® BALL VALVES

Cv FACTORS FOR APOLLO VALVES (continued from M-3)

VALVE	SIZE (IN.)														
	1/4	3/8	1/2	3/4	1	1.25	1.5	2	2.5	3	4	6	8	10	12
77C-100/200 Series	4.5	7.2	16	36	68	125	177	389	503	--	--	--	--	--	--
77D-140 Series	4.5	7.2	16	36	68	125	177	389	--	--	--	--	--	--	--
77D-640 Series	--	--	--	11	24	35	--	--	--	--	--	--	--	--	--
77G-UL Series	4.5	7.2	16	36	68	125	177	389	503	--	--	--	--	--	--
77W Series	--	--	16	36	68	125	177	389	--	--	--	--	--	--	--
77-100/200 Series	8.1	15	15	51	68	125	177	389	503	--	--	--	--	--	--
79 Series	8.5	8.5	9.8	32	44	66	148	218	440	390	--	--	--	--	--
80 Series	8.4	7.2	15	30	43	48	84	108	190	370	--	--	--	--	--
82-100/200 Series	8.1	14	26	51	68	120	170	376	510	996	1893	--	--	--	--
83A/83B Series	8.1	14	26	51	68	120	170	376	--	--	--	--	--	--	--
83R-100/200 Series	--	--	--	--	--	--	170	376	--	996	1893	--	--	--	--
86A/86B Series	8.1	14	26	51	68	120	170	376	--	--	--	--	--	--	--
86R-100/200 Series	--	--	--	--	--	--	170	376	--	996	1893	--	--	--	--
87A-100 Series	--	--	--	--	--	--	86	104	234	375	673	1099	1902	3890	--
87A-200 Series	--	--	15	19	75	--	195	410	545	1021	2016	4837	9250	15170	22390
87A-700 Series	--	--	--	--	--	--	86	104	234	375	673	1099	1902	3890	--
87A-900 Series	--	--	15	19	75	--	195	410	545	1021	2016	4837	9250	15170	22390
87A-F00 Series	--	--	--	--	75	--	195	410	545	1021	2016	4837	--	--	--
87B-100 Series	--	--	--	--	--	--	--	--	375	673	1099	1902	3890	--	--
87J-100 Series	--	--	--	--	--	--	86	104	234	375	673	1099	1902	3890	--
87J-200 Series	--	--	15	19	75	--	195	410	545	1021	2016	4837	9250	15170	22390
87J-700 Series	--	--	--	--	--	--	86	104	234	375	673	1099	1902	3890	--
87J-900 Series	--	--	15	19	75	--	195	410	545	1021	2016	4837	9250	15170	22390
87K-100 Series	--	--	--	--	--	--	86	104	234	375	673	1099	1902	3890	--
87K-200 Series	--	--	15	19	75	--	195	410	545	1021	2016	4837	9250	15170	22390
87K-700 Series	--	--	--	--	--	--	86	104	234	375	673	1099	1902	3890	--
87K-900 Series	--	--	15	19	75	--	195	410	545	1021	2016	4837	9250	15170	22390
88A-100 Series	--	--	--	--	--	--	86	104	234	375	673	1099	1902	3890	--
88A-200 Series	--	--	15	19	75	--	195	410	545	1021	2016	4837	9250	15170	22390
88A-700 Series	--	--	--	--	--	--	86	104	234	375	673	1099	1902	3890	--
88A-900 Series	--	--	15	19	75	--	195	410	545	1021	2016	4837	9250	15170	22390
88A-F00 Series	--	--	--	--	75	--	195	410	545	1021	2016	4837	--	--	--
88B-100 Series	--	--	--	--	--	--	--	--	375	673	1099	1902	3890	--	--
89-100 Series	8.4	7.2	15	30	43	48	84	108	190	370	--	--	--	--	--
9A-100 Series	8.3	6.7	5.7	10	16	25	40	62	--	--	--	--	--	--	--
90-100 Series	8.3	6.7	5.7	10	16	25	40	62	--	--	--	--	--	--	--
92-100 Series	8.3	6.7	5.7	10	16	25	40	62	--	--	--	--	--	--	--
93-100 Series	8.3	6.7	5.7	10	16	25	40	62	--	--	--	--	--	--	--
94A-100/200 Series	6	7	19	34	50	104	268	309	629	1018	1622	--	--	--	--
96-100 Series	8.3	6.7	5.7	10	16	25	40	62	--	--	--	--	--	--	--
399-100 Series	8.4	7.2	15	30	43	48	84	108	190	370	--	--	--	--	--
489-100 Series	8.4	7.2	15	30	43	48	84	108	190	370	--	--	--	--	--

1000 CWP

(CS) ASTM A216-WCB

GRAPH 7

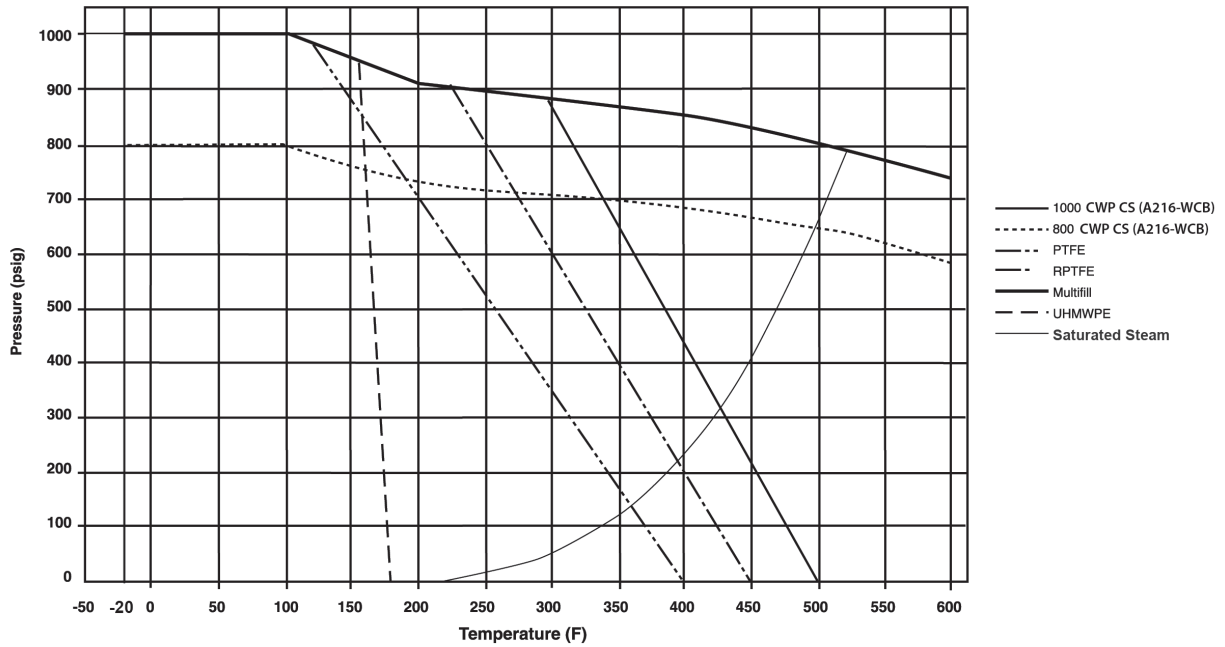

1000 CWP

(SS) ASTM A351-CF8M

GRAPH 8

