

For Residential and Commercial Applications

Job Name		Engineer / Architect	
Job Location		Wholesaler	
Submittal Date		Contractor	

68 Series Compression x Male Iron Pipe Adapters

Use: For use with instrumentation, hydraulic and pneumatic systems. Designed for use with aluminum, copper and plastic tubing. Not intended for use with steel tubing

* Plastic tubing requires a plastic insert and a sleeve (see 60PT & 63PT submittal forms for details)

Design Features:

- **Little to no tube preparation.** Compression fittings do not require flaring, soldering or other types of tube preparation
- **Available in a broad range of sizes**
- **Compliant fitting options** available for California and Vermont “low-lead” requirements

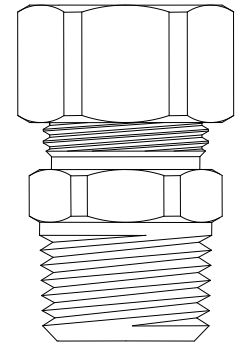

Operating Specifications:

- Temperature:** -65° - 250°F at maximum operating pressures
Working Pressure: See chart below
Vibration: Fair vibration resistance

WORKING PRESSURE		
PSI	Tube O.D.	Tube Wall (Inches)
400	1/8	0.030
400	3/16	0.030
300	1/4	0.030
300	5/16	0.032
200	3/8	0.032
200	1/2	0.032
150	5/8	0.035
100	3/4	0.035
75	7/8	0.035

Standard Fitting

MATERIAL SPECIFICATIONS	
Fitting Body	C36000 brass
Compression Sleeve	C36000 brass
Compression Nut	C36000 brass
Option	Chrome plating

Compliant Fitting

MATERIAL SPECIFICATIONS	
Fitting Body	Compliant brass
Compression Sleeve	C36000 brass
Compression Nut	C36000 brass
Option	Chrome plating

Standard Part Listing:

- 68-2-2 1/8" OD Tube x 1/8" M.I.P.
- 68-2-2 B 1/8" OD Tube x 1/8" M.I.P., bulk
- 68-2-2-1 B 1/8" OD Tube x 1/8" M.I.P. - body only, bulk

This specification and all information contained herein is the confidential and exclusive property of BrassCraft Manufacturing, and shall not be disclosed to others without the written consent of BrassCraft. This specification must be returned to BrassCraft if requested.



68 Series Compression x Male Iron Pipe Adapters

Standard Part Listing (con't):

- 68-4-4 1/4" OD Tube x 1/4" M.I.P.
- 68-4-4 B 1/4" OD Tube x 1/4" M.I.P., bulk
- 68-4-4-1 B 1/4" OD Tube x 1/4" M.I.P. - body only, bulk
- 68-6-6 3/8" OD Tube x 3/8" M.I.P.
- 68-6-6 B 3/8" OD Tube x 3/8" M.I.P., bulk
- 68-6-6-1 B 3/8" OD Tube x 3/8" M.I.P. . - body only, bulk
- 68-6-6-1 CB 3/8" OD Tube x 3/8" M.I.P. . - body only, chrome plated, bulk
- 68-8-8 1/2" OD Tube x 1/2" M.I.P.
- 68-8-8 B 1/2" OD Tube x 1/2" M.I.P., bulk
- 68-8-8 C 1/2" OD Tube x 1/2" M.I.P., chrome plated
- 68-8-8-1 B 1/2" OD Tube x 1/2" M.I.P. - body only, bulk
- 68-12-12 3/4" OD Tube x 3/4" M.I.P.
- 68-12-12-1 B 3/4" OD Tube x 3/4" M.I.P. - body only, bulk

Compliant Part Listing:

- 68-4-4X 1/4" OD Tube x 1/4" M.I.P.
- 68-6-6X 3/8" OD Tube x 3/8" M.I.P.
- 68-6-6X C 3/8" OD Tube x 3/8" M.I.P., chrome plated
- 68-6-6X CB 3/8" OD Tube x 3/8" M.I.P., chrome plated, bulk
- 68-8-8X 1/2" OD Tube x 1/2" M.I.P.
- 68-8-8-1X B 1/2" OD Tube x 1/2" M.I.P. - body only, bulk

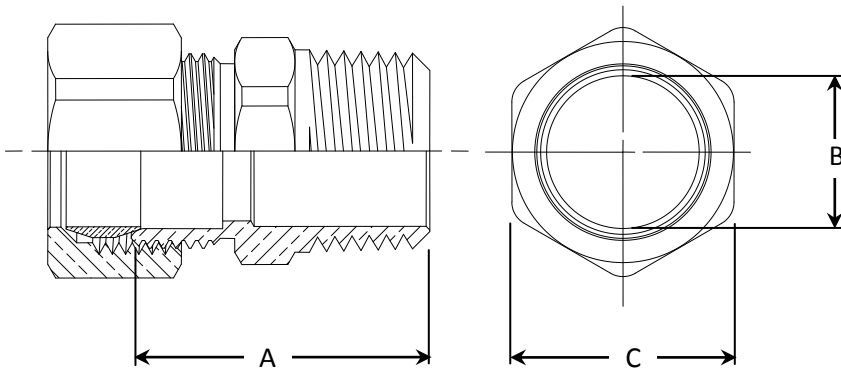

Listings & Certifications:

- Compliant product CSA approved to California Health & Safety Code and Vermont Bill S.152 (Project # 2174785)



PART DIMENSIONS (Inches)			
Model	DIM. A	DIA. B	DIM. C
68-2-2	0.79	0.94	7/16
68-4-4	0.88	0.187	9/16
68-6-6	1.06	0.312	11/16
68-8-8	1.22	0.437	7/8
68-12-12	1.38	0.562	1-1/16

This specification and all information contained herein is the confidential and exclusive property of BrassCraft Manufacturing, and shall not be disclosed to others without the written consent of BrassCraft. This specification must be returned to BrassCraft if requested.

BrassCraft[®]