

Style SSB-7

Y-Strainer

Stainless Steel (ASTM A 351, Grade CF8M)

600 lb. Threaded

600 lb. Socket Weld



Cast 316 Stainless Steel Y-Strainer

APPLICATIONS

Steam, water, oil or gas where protection from foreign matter in a pipeline is required.

CONSTRUCTION

The Keckley Style SSB-7 strainers are constructed from rugged 316 stainless steel castings that are machined to exacting specifications.

Socket Weld bore is in compliance with ASME B16.11 unless otherwise specified.

FEATURES

The Keckley Style SSB-7 strainer features a machined groove in the body and cap for proper alignment and to ensure accurate reseating when servicing is required. This strainer has a straight threaded cap and is furnished standard with a NPT blow-off connection. The gasket is 304 stainless steel spiral wound and is compressed between the body and cap (for maximum strength and durability) and designed for both high pressure and high temperature service. Keckley Style SSB-7 strainers can be supplied with a stainless steel blow-off plug upon request.

SCREENS

Standard perforated 304 stainless steel screens are spot welded along the seam for maximum strength. Different size perforations and meshes are available in stainless steel, monel, and brass to meet specific media requirements. If media is not indicated, screens for *steam* will be supplied.

SELF CLEANING

Self cleaning is accomplished by opening the valve or drain plug connected to the blow-off port. **Warning:** See Maintenance Instructions on page S6 of the Strainer Information Section for additional precautions and detailed information on servicing the strainer.

WORKING PRESSURES - NON SHOCK

NOM. RATING	MEDIA	1/4" to 3"	8 mm to 80 mm
600# (THREADED & SOCKET WELD)	STEAM	600 PSI @ 1125°F	4138 KPa @ 607°C
	W.O.G.	1440 PSI @ 100°F	9932 KPa @ 38°C

Style SSB-7

Y-Strainer, 600 lb. Threaded & Socket Weld
Stainless Steel (ASTM A 351, Grade CF8M)

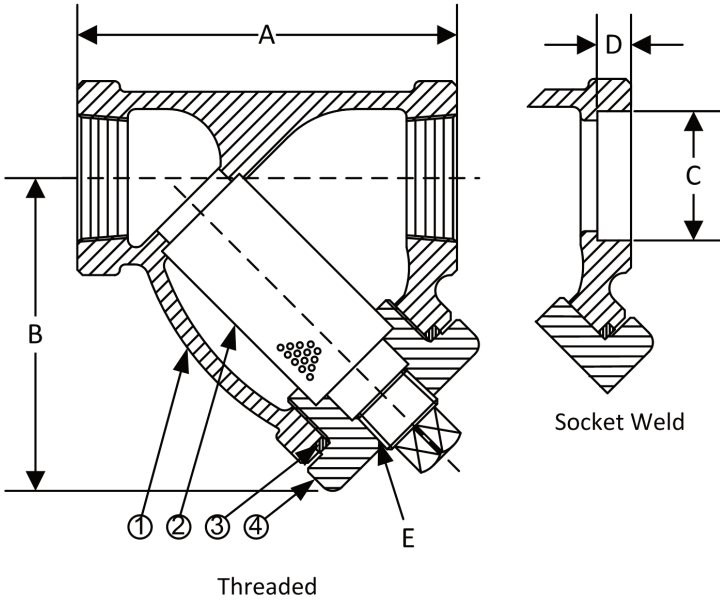

PARTS LIST		
ITEM	DESCRIPTION	MATERIAL
1	Body	Stainless Steel (ASTM A 351, Grade CF8M)
2	Screen	Stainless Steel (304)
3	Gasket	Spiral Wound Stainless Steel (304)
4	Cap	Stainless Steel (ASTM A 351, Grade CF8M)

Optional: Blow-off Plug, Carbon Steel (ASTM A 105).
*Optional Body Materials Available in 304 and 400 Series SS, Alloy 20, Hastelloy, Inconel, Monel and Stellite..

SIZE		SCREEN GAGE	SCREEN PERFORMANCE					
in	mm		FOR STEAM	OPEN AREA	FOR LIQUID	OPEN AREA		
1/4 to 3	8 to 80	22	3/64	1.2	33%	1/16	1.6	30%

Standard screens supplied are for **steam service**, unless otherwise specified.
Options: Other perforations, meshes, and screen materials are available.

SIZE		DIMENSIONS										WEIGHTS	
in	mm	A		B		C		D		E		lbs	kgs
		in	mm	in	mm	in	mm	in	mm	in	mm		
1/4	8	2-15/16	75	2-7/16	62	0.555	14	3/8	10	1/4	8	3	1
3/8	10	2-15/16	75	2-7/16	62	0.690	18	3/8	10	1/4	8	3	1
1/2	15	2-15/16	75	2-7/16	62	0.855	22	3/8	10	1/4	8	3	1
3/4	20	3-11/16	94	3	76	1.065	27	1/2	13	3/8	10	5	2
1	22	4-9/16	116	4-5/16	110	1.330	34	1/2	13	3/8	10	6	3
1-1/4	32	4-15/16	125	4-3/16	106	1.675	43	1/2	13	3/4	20	8	4
1-1/2	40	5-9/16	141	4-11/16	119	1.915	49	1/2	13	3/4	20	10	5
2	50	6-15/16	176	6-1/4	159	2.406	61	5/8	16	1	25	16	7
2-1/2	65	12	305	9-3/8	238	2.906	74	5/8	16	1-1/4	32	43	20
3	80	12	305	9-3/8	238	3.535	90	5/8	16	1-1/4	32	43	20

Certified dimensional drawings are available upon request.

†This table reflects only the nearest metric equivalents.

FLOW COEFFICIENTS

Size	C _v	Size	C _v	Size	C _v
1/4"	9.5	1"	30	2-1/2"	129.7
3/8"	9.5	1-1/4"	44.9	3"	161.3
1/2"	9.5	1-1/2"	61		
3/4"	18.7	2"	98		

TOTAL SCREEN AREA

Size	(in ²)	Size	(in ²)	Size	(in ²)
1/4"	2.75	1"	10.08	2-1/2"	78.14
3/8"	2.75	1-1/4"	12.79	3"	78.14
1/2"	2.75	1-1/2"	16.33		
3/4"	4.71	2"	27.04		

*See DETERMINING RATIOS on page S5 of the Strainer Information Section for calculating NET FREE AREA of the screen to inside pipe area.

PRESSURE vs. TEMPERATURE CHART

600# Threaded & Socket Weld Stainless Steel (ASTM A 351, Grade CF8M)

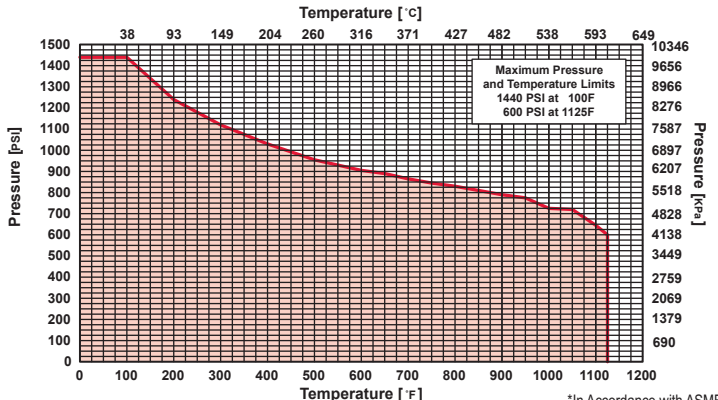

*In Accordance with ASME B16.34



PRESSURE DROP CHART

Threaded “Y” Pattern Strainers (Styles B, BDI, E-150, F-150, F-300, SB, SB-7, SSB and SSB-7)

This pressure drop chart is based on the flow of clean water through the Keckley “Y” strainers listed above with screen perforations ranging from 3/64” through 1/8” and is additionally for use with those units equipped with a 20 mesh screen as standard.

TO USE CHARTS:

Find your desired rate of flow (GPM) on the left hand side of the chart. Follow its corresponding horizontal line to the point where it intersects the diagonal line indicating the strainer pipe size. From this point of intersection, follow the vertical line down to the bottom of the chart to determine the approximate pressure drop.

CORRECTION FACTORS:

For finer mesh screens that are backed with a perforated sheet, multiply the pressure drops shown at right by the following:

- 40 mesh x 1.2
- 60 mesh x 1.4
- 80 mesh x 1.6
- 100 mesh x 1.7

