

Viega MegaPress Stainless System Installation Manual



The global leader
in plumbing, heating
and pipe joining systems

viega



Heritage of quality, vision for the future

Viega's heritage of superiority demands nothing but the best for our customers. Engineered to be efficient, Viega products perform at the highest possible level, providing confidence and peace of mind. Viega is the only manufacturer to offer press systems in multiple pipe joining materials. More than one million Viega press fittings are installed every day around the world and, with a Supply Chain that can process orders in 48 hours or less, Viega is positioned to provide customers with the best, most versatile support in the industry.

Introducing the Viega MegaPress Stainless system

Viega is proud to introduce the next evolution of its innovative press technology: Viega MegaPress stainless steel.

Viega MegaPress customers all over the world have already reduced their installation and repair times with steel pipe by up to 90%. Whether they are carbon steel, 304 stainless steel or 316 stainless steel, Viega MegaPress fittings require no threading, no messy cutting oil, no welding, and pose no fire hazard. The days of spending hours to complete one stainless weld joint are over. With MegaPress stainless fittings, the connection is completed in less than seven seconds.

The new Viega MegaPress stainless steel fittings are available in both 304 and 316 and are for use with off-the-shelf schedule 5 to schedule 40 stainless steel pipe. Viega MegaPress fittings install quickly and easily with a simple pressing tool. They drastically reduce system downtime, potentially avoiding system shutdowns entirely when making improvements or repairs.

These stainless steel fittings are suitable for a broad range of industrial uses, including fuel oils, acids, complex chemicals and inert gases.

With MegaPress stainless steel, Viega brings its innovative, versatile MegaPress technology to customers in an exciting new way.

Do more with Viega

Viega press technology is consistent and reliable, providing the same quality pipe connections every time. Viega press systems make secure connections in less than seven seconds, which helps keep a project on time or ahead of schedule. The Viega MegaPress system helps installers accomplish more in the same amount of time.

A true innovator since 1899, Viega is at the forefront of pipe joining technology. With personalized support, efficient delivery processes and trustworthy quality, no other manufacturer can provide the same level of service. The global leader in plumbing, heating and pipe joining systems, Viega is the name you can trust.

IMPORTANT NOTE:

A GREEN DOT ON A VIEGA MEGAPRESS FITTING INDICATES THE SMART CONNECT TECHNOLOGY WITH AN EPDM SEALING ELEMENT. FOR A CURRENT LIST OF APPLICATIONS, PLEASE VISIT WWW.VIEGA.US/APPLICATIONS.

A WHITE DOT ON A VIEGA MEGAPRESS FITTING INDICATES THE SMART CONNECT TECHNOLOGY WITH AN FKM SEALING ELEMENT. FOR A CURRENT LIST OF APPLICATIONS, PLEASE VISIT WWW.VIEGA.US/APPLICATIONS.

Viega products are designed to be installed by licensed and trained plumbing and mechanical professionals who are familiar with Viega products and their installation. *Installation by non-professionals may void Viega LLC's warranty.*



1 System Description

- 1.1 Viega MegaPress stainless 304 4
 - 1.1.1 Approvals and certifications 4
 - 1.1.2 Codes 4
- 1.2 Viega MegaPress stainless 316 4
 - 1.2.1 Approvals and certifications 4
 - 1.2.2 Codes 4
- 1.3 Fitting description 5
 - 1.3.1 Viega Smart Connect technology 5
 - 1.3.2 Sealing elements 6
 - 1.3.3 Fitting markings 6
- 1.4 Applications 7

2 Tools

- 2.1 Tools 8
- 2.2 Pressing tools 8

3 General Installation Instructions

- 3.1 Pipe selection 9
- 3.2 Handling instructions 9
- 3.3 Pipe preparation 9
 - 3.3.1 No-stop couplings 9
- 3.4 Pressing requirements 10
 - 3.4.1 Minimum distance between fittings 10
 - 3.4.2 Pressing in tight quarters 10
 - 3.4.3 Minimum space requirements for the press fitting process in front of and behind components 11
 - 3.4.4 Pressing with ring and actuator in tight quarters 12
- 3.5 Welding requirements 13
 - 3.5.1 Welding adjacent to Viega MegaPress stainless fittings 13
 - 3.5.2 Welding in line with Viega MegaPress stainless fittings 13
- 3.6 General installation requirements 13
 - 3.6.1 Expansion 13
 - 3.6.2 Electrical bonding 13
 - 3.6.3 Piping exposed to freezing temperatures 13
 - 3.6.4 Corrosion protection 13
 - 3.6.5 Underground installations 13
 - 3.6.6 Pressure testing 13
 - 3.6.7 Threaded connections 13
 - 3.6.8 Flange connections 13
 - 3.6.9 Pipe hangers 13
- 3.7 Deflection 14
- 3.8 Identification 15
- 3.9 Viega MegaPress Stainless Steel Pipe Marking Guide 15
- 3.10 Viega MegaPress Stainless fitting system ½" to 2" installation 16

4 Warranty 19

1 System Description

The Viega MegaPress stainless fitting system is a state-of-the-art IPS press fitting system that provides an economical and reliable installation of schedule 5 to schedule 40 ASTM A312 stainless steel pipes. Viega MegaPress fittings are available in sizes ranging from ½" to 2" and provide a fast, reliable, consistent joining method.

Our products are the result of decades of experience in manufacturing press fittings. The Viega MegaPress stainless fitting system is offered in configurations that allow for the installation of the vast majority of stainless steel piping applications in the commercial and industrial markets.

The Viega MegaPress stainless fitting system requires no threading or welding and poses no fire hazard, which is particularly important in restoration or retrofit work. The press fittings are installed with a battery-powered or corded pressing tool.

The advantages of installing Viega MegaPress stainless fitting system include:

- Most labor savings
- Lowest overall installed cost
- Proven joining technology
- Technical field support
- No fire watch needed
- No special certification required

1.1 Viega MegaPress stainless 304

Viega MegaPress stainless 304 ½" to 2" fittings feature an FKM sealing element suitable for the following applications:

- Hydronic heating (with glycol)
- Chilled water
- Compressed air
- Low-pressure steam (15 psi max.)
- Vacuum (29.2 in Hg max.)
- Process water
- Fuel oils
- Caustic solutions
- Acid solutions

For more information, see Table 1.1 Approved Applications on Page 7.

1.1.1 Approvals and certifications

- ICC-LC1002
- IAPMO/PS117
- TSSA-ASME B31

1.1.2 Codes

- ASME B31, 31.1, 31.3, 31.9
- ICC International Plumbing Code
- ICC International Mechanical Code
- IAPMO Uniform Plumbing Code
- IAPMO Uniform Mechanical Code
- PHCC National standard plumbing code

1.2 Viega MegaPress stainless 316

Viega MegaPress stainless 316 ½" to 2" fittings have a factory-installed EPDM sealing element suitable for the following applications.

- Hydronic heating (with glycol)
- Chilled water
- Compressed air
- Low-pressure steam (15 psi max.)
- Vacuum (29.2 in Hg max.)
- Process water
- Caustic solutions
- Acid solutions
- Potable water

For more information, see Table 1.1 Approved Applications on Page 7.

1.2.1 Approvals and certifications

- NSF-372-61
- ICC-LC1002
- IAPMO/PS117
- TSSA-ASME B31

1.2.2 Codes

The major codes and standards regulating stainless steel piping systems include:

- ASME B31, 31.1, 31.3, 31.9
- ICC International Plumbing Code
- ICC International Mechanical Code
- IAPMO Uniform Plumbing Code
- IAPMO Uniform Mechanical Code
- PHCC National standard plumbing code

Note: All systems must be installed per local code requirements.

1.3 Fitting description

Viega MegaPress fittings contain a stainless steel grip ring and 304 stainless steel separator ring as shown in Figure 1.1. The grip ring is a 420 stainless steel ring with bidirectional teeth that grip the pipe and ensure that the fitting is locked securely to the piping.

The 304 stainless steel separator ring ensures that the sealing element and grip ring perform at maximum capacity by providing a positive physical separation.

Press jaws and actuator rings are available for various dimensions. Their constant compression produces a positive, nondetachable, mechanical joint.

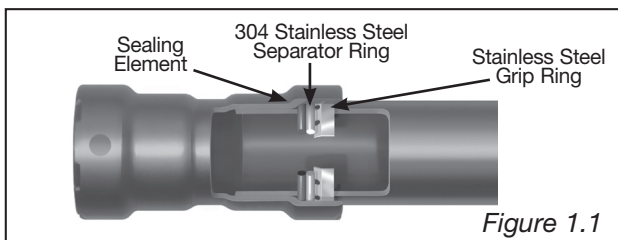

Figure 1.1

1.3.1 Viega Smart Connect technology

Viega MegaPress stainless systems, sizes ½" through 2", incorporate Viega Smart Connect technology. Smart Connect is a patented technology, third-party tested, proven to identify unpressed connections during a step test.

Smart Connect allows liquid or gaseous testing media to bypass the sealing element of an unpressed connection. This provides a quick and easy method to identify unpressed connections before system commissioning.

To utilize Smart Connect technology prior to commissioning, pressurize the system with 15-85 psi water or air and observe the pressure gauge. If the system will hold 15-85 psi, you may then continue to pressurize the system to local code or specified requirements or standards, up to 600 psi. If the system will not hold 15-85 psi there is either an opening in the system or a connection has been left unpressed. Utilize standard detection procedures to locate the unpressed connection. Once found, you may press the connection during the test after ensuring full insertion depth of the piping into the fitting. Testing the system for unpressed connections using Viega Smart Connect technology is in no way meant as a replacement for testing to local code or specified requirements or standards for the installed system.

Unpressed connections in press systems without Viega Smart Connect technology may not leak initially; however, they may unseat during future system operation. Viega Smart Connect technology is designed to prevent this potential risk.



1 Identify an unpressed connection during pressure testing when water flows past the sealing element.

2 Upon identification, use the Viega MegaPress tool to press the fitting, making a reliable leak-proof connection.

3 Viega MegaPress connections are fast, flameless and reliable.

Figure 1.2 Smart Connect technology

1.3.2 Sealing elements

Viega MegaPress Stainless 316 EPDM Sealing Element

Operating temperature: 0°F to 250°F (-18°C to 120°C)

This sealing element is used mainly in the applications of hydronic heating, chilled water and fire sprinkler installations. EPDM, or ethylene-propylene-diene monomer, is shiny black in color. The EPDM sealing element is a synthetically manufactured and peroxidically cross-linked general-purpose elastomer with a wide range of applications.

The EPDM sealing element possesses excellent resistance to aging, ozone, sunlight, weathering, environmental influences, alkalis and most alkaline solutions and chemicals used in a broad range of applications.

Viega MegaPress Stainless 304 FKM Sealing Element

Operating temperature: 14°F to 284°F (-10°C to 140°C)

FKM is well known for its excellent resistance to petroleum products and solvents as well as exceptional high-temperature performance.

The FKM sealing element is a special-purpose elastomer typically installed where higher temperatures are required.

FKM, a fluoroelastomer, is dull black in color. It possesses excellent resistance to aging, ozone, sunlight, weathering, environmental influences,

oils and petroleum-based additives. Its superb resistance to high temperatures and petroleum-based additives makes it ideal for seals and gaskets in solar, district heating, low-pressure steam and compressed air system fittings. It can withstand heat spikes up to 356°F.

Note: All sealing elements are installed using an H-1 food grade silicone oil lubricant registered with NSF, USDA and approved for use under FDA 21 CFR.

Note: Refer to product line application guides or chemical compatibility matrix for general information, or call Viega Tech Services at 1-877-843-4262.

1.3.3 Fitting markings

Markings on Viega MegaPress stainless 304 fittings include:

- White Dot: FKM sealing element and Smart Connect feature
- Size of fitting
- Manufacturer name
- Manufacturer date code
- Country of origin
- Batch code

Markings on Viega MegaPress stainless 316 fittings include:

- Green Dot: EPDM sealing element and Smart Connect feature
- Size of fitting
- Manufacturer name
- Manufacturer date code
- Country of origin
- Batch code

1.4 Applications

Listed below are common applications approved by Viega for Viega MegaPress stainless fitting systems.

Types of Service	System Operating Conditions			MegaPress 304 Stainless	MegaPress 316 Stainless
	Comments	Pressure	Temperature	FKM	EPDM
Fluids/Water					
Potable water		200 PSI	32°F to 250°F		√
Cooling water	Up to 50% ethylene glycol or propylene glycol solution	200 PSI	*See Note 2	√	√
Hydronic heating	Ethylene glycol / propylene glycol	200 PSI	Up to 250°F	√	√
Process water (nonpotable)		200 PSI	*See Note 2	√	√
Wastewater/Greywater	No blackwater waste	200 PSI	*See Note 2	√	√
RO and DI water	1 mega ohm max for RO	200 PSI	32°F to 250°F		√
Low-pressure steam/ condensate		Up to 15 PSI	248°F	√	√
Glycol		200 PSI	*See Note 2	√	√
Fuel, Oil and Lubricant					
Lube oils	Petroleum based	150 PSI	14°F to 200°F	√	
Fuel oils		150 PSI	14°F to 200°F	√	
Gases					
Compressed air	Less than 25mg/m ³ oil content	200 PSI	Ambient	√	√
Compressed air	More than 25mg/m ³ oil content	200 PSI	Ambient	√	
Instrument air	Nonmedical	200 PSI	Ambient	√	
Argon	Welding use	200 PSI	Up to 140°F	√	√
Nitrogen		200 PSI	Up to 140°F	√	√
Oxygen - O ₂ (nonmedical)	Keep oil and fat free/ nonliquid O ₂	145 PSI	Up to 140°F	√	
Methane gas		70 PSI	Up to 140°F	√	
Carbon dioxide		200 PSI	*See Note 2	√	√
Ammonia	Anhydrous	200 PSI	122°F		√
Hydrogen - H ₂		125 PSI	0°F to 250°F		√
Miscellaneous					
Vacuum		Max. 29.2 in Hg	Up to 140°F	√	√
Mixed chemical drains	Depending on temp/ concentration			√	√
Caustic solutions	Depending on temp/ concentration			√	√
Acid solutions	Depending on temp/ concentration			√	√
1. Consult the Viega Technical Support Department for information on applications not listed and applications outside the temperature and pressure ranges listed above.					
2. System pressure and temperature ranges depend on sealing element.					

Table 1.1 Approved Applications

2 Tools

2.1 Tools

Viega recommends RIDGID press tools, Viega MegaPress jaws and ring sets and RIDGID pipe preparation tools manufactured and sold by Ridge Tool Company for use with Viega Systems.

Viega MegaPress products carry a limited warranty against defects in material and workmanship. The RIDGID lifetime warranty applies to tools, jaws and press rings from The Ridge Tool Company. For more information, contact Ridge Tool Company at 1-888-743-4333 or visit www.RIDGID.com.

2.2 Pressing tools

The following RIDGID pressing tools are available for the Viega MegaPress Stainless pressing systems:

- RP 340-B Battery Powered Press Tool
- RP 330-B Battery Powered Press Tool
- RP 330-C Corded Press Tool
- RP 320 Battery Powered Press Tool
- CT 400 Corded Press Tool



RP 330-B
1/2" - 2"



RP 330-C
1/2" - 2"



V2 Actuator and Viega MegaPress Jaws
Jaws 1/2" - 1"
Ring Set 1 1/4" - 2"



RP 340-B
1/2" - 2"

RIDGID® is a registered trademark of the Ridge, Inc.

3.1 Pipe selection

Viega MegaPress stainless 1/2" to 2" fittings are compatible with ASTM A312 stainless steel pipe, schedule 5 to schedule 40.

3.2 Handling instructions

Viega MegaPress stainless components shall be free from dirt, debris or items that may interfere with the sealing element and the press connection. Pipe shall be cut using a pipe cutter or metal saw. It is not acceptable to cut the pipe with an abrasive cutting wheel or torch.

3.3 Pipe preparation

Pipe surfaces must be smooth, free of indentations, pits and deformations and must be clean and free of debris, rust, oil and grease.

Pipe ends are to be square and de-burred internally and externally. The pipe end shall be prepped to the proper insertion depth. See Table 3.1.

To avoid leak paths, engraved or stamped pipe shall not be used with the Viega MegaPress stainless fitting system.

Engraving or stamping shall not be removed through use of a grinder or other tool.

Viega MegaPress sealing elements, separator rings and grip rings are to be visually inspected prior to installation to ensure the seal is intact and properly located within the fitting. See "1.3 Fitting description" on page 5 for more information. Viega MegaPress stainless sealing elements may not be removed or replaced.

The Viega MegaPress stainless system does not require lubrication of the pipe or the fitting. Proper insertion depth must be marked on the pipe. Refer to Table 3.1. Improper insertion depth may result in an improper seal. The depth marking shall be visible on the completed assembly.

3.3.1 No-stop couplings

No-stop couplings are often used to conduct repairs. Without a stop, these couplings can slide completely onto a pipe and allow a connection to be made in tighter spaces. Unlike fittings with an integrated stop that have a minimum insertion depth, no-stop couplings have minimum and maximum allowable insertion depths. Both the minimum and the maximum insertion depths must be marked and a line connecting the two marks. Drawing a line between the minimum and maximum insertion marks distinguishes a good connection on a no-stop fitting from a bad connection on a fitting with a stop.

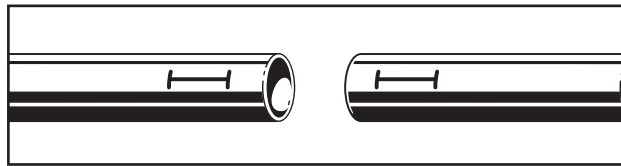

Viega MegaPress Stainless No-Stop Couplings				
Pipe Diameter	Minimum Insertion		Maximum Insertion	
	in	mm	in	mm
1/2"	1 1/16"	27.2	1 5/8"	41
3/4"	1 3/16"	29.4	1 13/16"	46
1"	1 3/8"	34.2	1 15/16"	49
1 1/4"	1 13/16"	46.2	2 1/2"	63
1 1/2"	1 7/8"	47.5	2 3/4"	70
2"	2"	50	2 3/4"	70

Table 3.2

Pipe Size	Insertion Depth	
	in	mm
1/2"	1 1/16	27.2
3/4"	1 3/16	29.4
1"	1 3/8	34.2
1 1/4"	1 13/16	46.2
1 1/2"	1 7/8	47.5
2"	2	50

Table 3.1

3.4 Pressing requirements

The following requirements must be considered when pressing Viega MegaPress stainless fittings.

3.4.1 Minimum distance between fittings

Space between fittings must be provided for the proper operation of the press jaw or press ring. (Refer to chart below.) Failure to provide this distance may result in an improper seal.

3.4.2 Pressing in tight quarters

The minimum distance between piping or the piping and the wall/ceiling construction must be taken into consideration in the planning phase for a problem-free work process. The following figures illustrate the clearance requirements for the jaws and fittings and the procedure for pressing fittings in tight quarters.

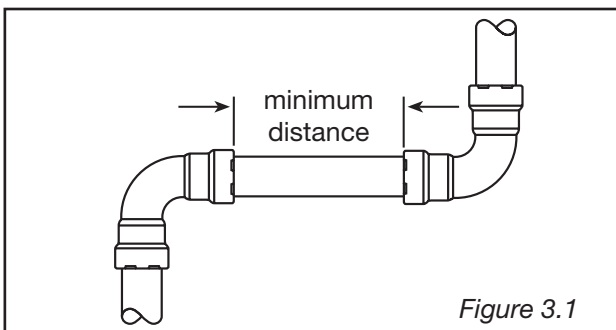

Figure 3.1

Minimum distance between two Viega MegaPress stainless press connections ½" to 2"		
Pipe Diameter	Minimum Distance (in)	Minimum Distance (mm)
½"	⅜	5
¾"	⅜	5
1"	⅜	5
1¼"	¾	10
1½"	¾	10
2"	¾	10

Table 3.3

Minimum distance requirements for press jaws between pipes and walls

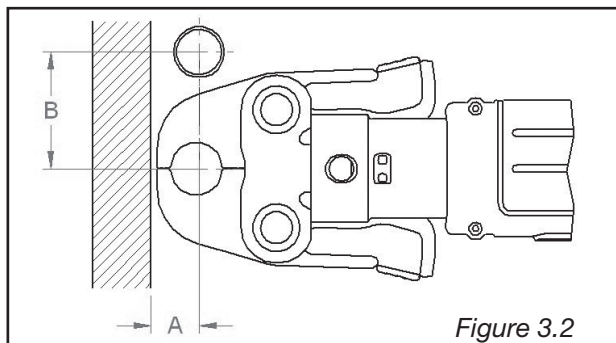

Figure 3.2

Pipe Diameter	A minimum	B minimum
	in	in
½"	1	2⅝
¾"	1¼	3⅛
1"	1¾	3⅝

Table 3.4

Minimum distance requirements for press jaws between pipes and wall/floor structure

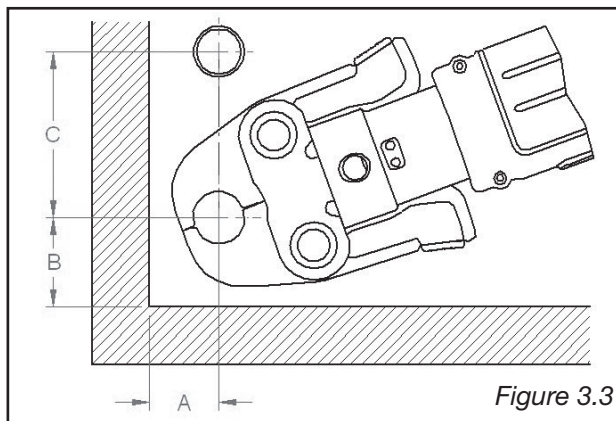

Figure 3.3

Pipe Diameter	A minimum	B minimum	C minimum
	in	in	in
½"	1¼	1⅞	3
¾"	1½	2⅞	3½
1"	2	2½	4

Table 3.5

3.4.3 Minimum space requirements for the press fitting process in front of and behind components

Ensure that the space required for Viega system pressing tools is available if press fittings will be executed immediately upstream and downstream from wall or ceiling penetrations.

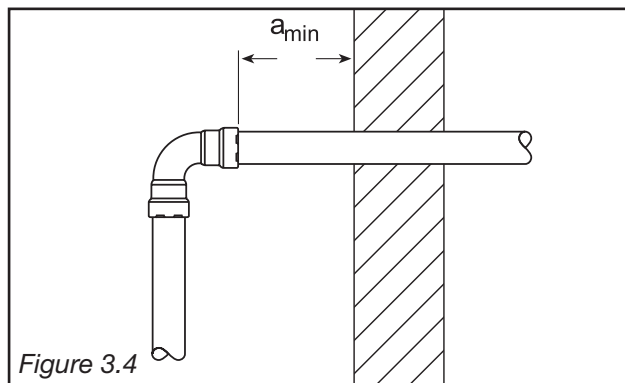
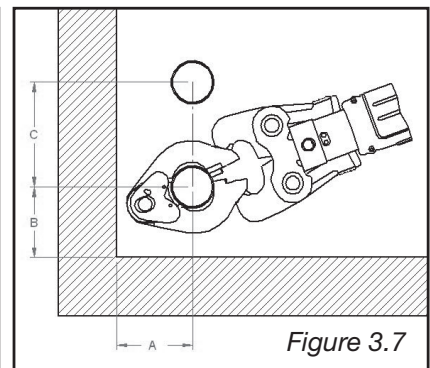
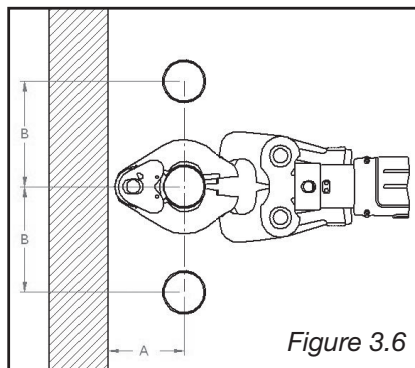
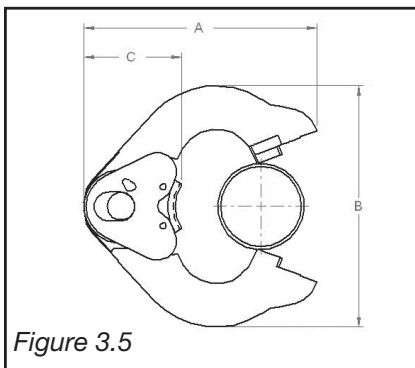
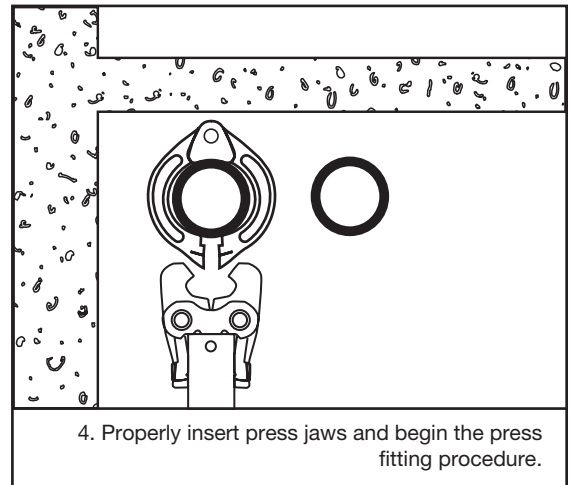
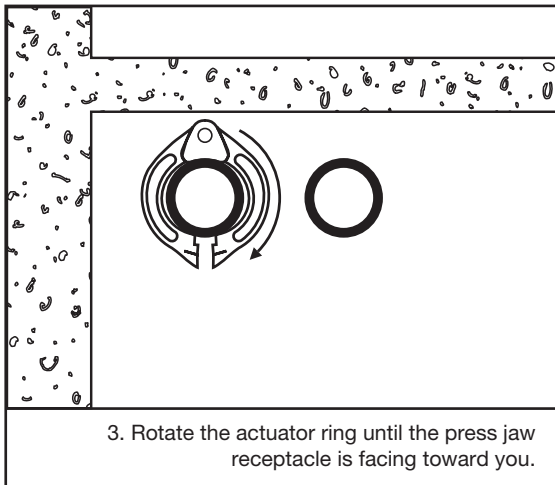
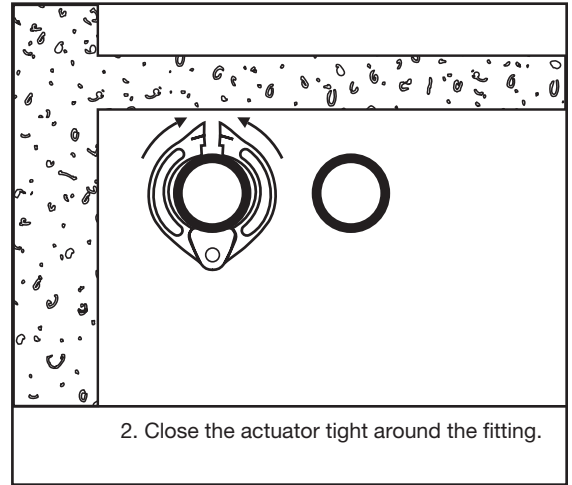
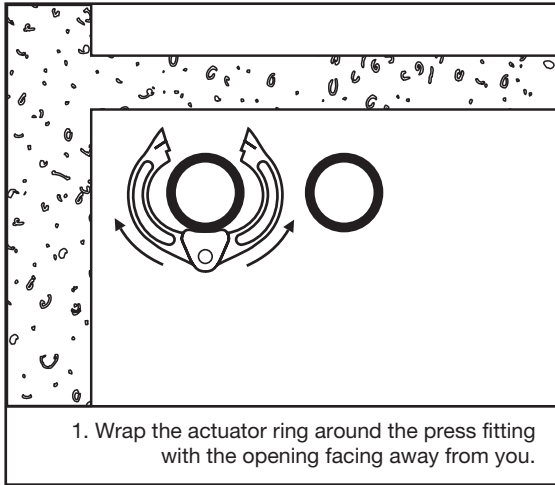

Figure 3.4

Pipe Size	Minimum space requirement, a_{min} for press tools
	RIDGID RP 330-B, 330-C and 340-B Press Tool (in)
1/2" to 1"	1 1/2"
1 1/4" to 2"	3/8"

Table 3.6

3.4.4 Pressing with ring and actuator in tight quarters



Pipe Diameter	A in	B in	C in
1¼"	6	6¼	2½
1½"	6	6¼	2⅝
2"	6	6⅝	2½

Table 3.7

Pipe Diameter	A in	B in
1¼"	3¾	4⅞
1½"	4	5⅞
2"	4	5⅞

Table 3.8

Pipe Diameter	A in	B in	C in
1¼"	3¾	3	4⅞
1½"	4	4	5⅞
2"	4	4	5⅞

Table 3.9

3.5 Welding requirements

The following requirements must be considered when welding in the same vicinity as Viega MegaPress stainless fittings.

3.5.1 Welding adjacent to Viega MegaPress stainless fittings

When welding adjacent to a Viega MegaPress connection, the installer must remain 4" away from the connection to prevent damage to the sealing element. The installer should take the following precautions to keep the Viega MegaPress stainless connection cool while welding:

- Wrapping the connection with a cold, wet rag
- Protecting the connection with a weld blanket
- Fabricating weld connections prior to installing the pressed fitting, making sure the pipe has cooled before installing the fitting
- Consistently applying heat sink gel or spray

3.5.2 Welding in line with Viega MegaPress stainless fittings

When welding in line with Viega MegaPress stainless fittings, the installer must remain a minimum of three feet away from the Viega MegaPress stainless connection to prevent damage to the sealing element. The installer should take the following precautions to keep the Viega MegaPress stainless connection cool while welding:

- Wrapping the connection with a cold, wet rag
- Protecting the connection with a weld blanket
- Fabricating weld connections prior to installing the pressed fitting, making sure the pipe has cooled before installing the fitting
- Consistently applying heat sink gel or spray

3.6 General installation requirements

The Viega MegaPress stainless fitting system must be installed while considering the following general industry requirements.

3.6.1 Expansion

Thermal expansion in installed systems generates stresses in pipes and appliance connectors. Compensation must be allowed for expansion and contraction that may occur within the piping system. Expansion joints or mechanical expansion compensators may be used to alleviate these stresses.

3.6.2 Electrical bonding

When properly installed, Viega MegaPress stainless fittings comply with Section 1211.15, Electrical Bonding and Grounding, of the Uniform Plumbing Code.

The mechanical press provides continuous metal-to-metal contact between fitting and pipe. The press ensures the continuity of the bonding through this contact.

3.6.3 Piping exposed to freezing temperatures

In the Viega MegaPress stainless system, the EPDM sealing element can be installed in ambient temperatures down to 0°F. The FKM sealing element can be installed in ambient temperatures down to 14°F. Piping systems exposed to freezing temperatures must be protected per acceptable engineering practices, codes and as required by the local authority.

3.6.4 Corrosion protection

Viega MegaPress stainless fittings exposed to corrosive action, such as soil conditions or moisture, must be protected in an approved manner in accordance with NACE Standard RP0169-2002 Section 5, 2009 UPC Chapter 6 Section 609.3.1, 2009 UMC Chapter 13 Section 1312.1.3 and in a manner satisfactory to the local code official.

Care should be taken to select hangers of suitable material that is galvanically compatible with the piping system. In addition, piping systems should be properly sized to minimize the risk of erosion corrosion resulting from excessive velocities.

3.6.5 Underground installations

Viega MegaPress stainless fitting systems are approved for underground installations. However, any installations must meet all state and local codes, including those for underground.

Proper authorization must be obtained prior to underground installation from the local authority having jurisdiction.

3.6.6 Pressure testing

The pressure testing of installed piping systems is to be completed in accordance with local codes or best engineering practices. MegaPress stainless fittings have a maximum test pressure of 600 psi.

3.6.7 Threaded connections

Viega MegaPress Stainless threaded fittings ½" to 2" shall be installed by tightening the threaded connection first, followed by making the press connection.

3.6.8 Flange connections

When using Viega flanges, bolt the flange end in place prior to pressing the fitting to the pipe.

3.6.9 Pipe hangers

Hangers and supports must conform to the requirements of ANSI/MSS SP 58, Pipe Hangers and Supports, Materials, Design, Manufacture, Selection, Application and Installation. Supports, hangers and anchors are to be installed in a manner that does not interfere with the free expansion and contraction of the piping.

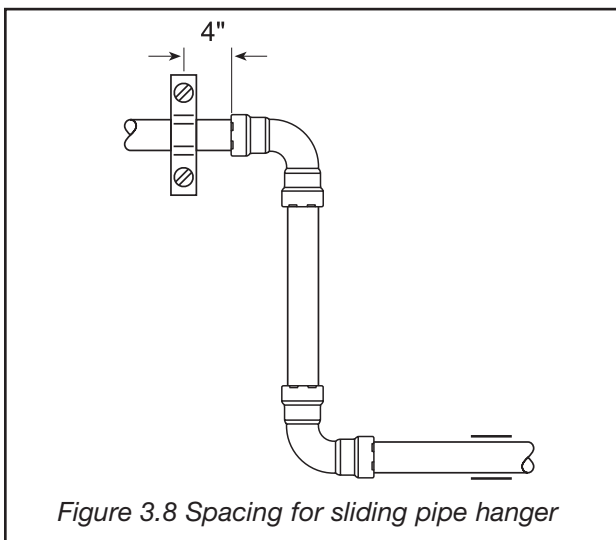

Figure 3.8 Spacing for sliding pipe hanger

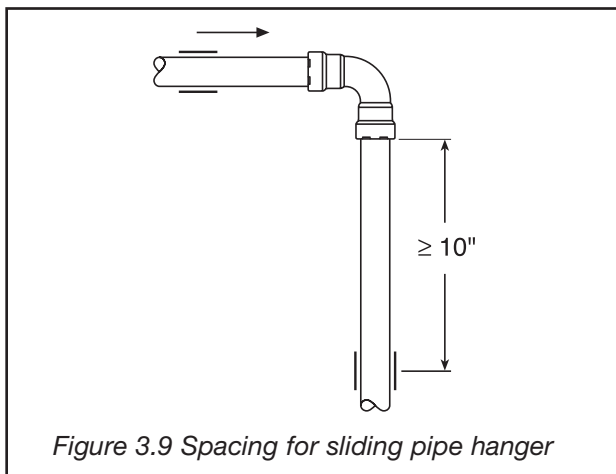

Figure 3.9 Spacing for sliding pipe hanger

Pipe Size (in)	Steel Pipe Max. Span (ft)	Min. Rod Diameter (in)
1/2 - 3/4	6	3/8
1	8	3/8
1 1/4 - 2	10	3/8

Table 3.10 Hanger Spacing

All parts of the support equipment need to be designed and installed to not disengage due to movement of the supported piping. Sliding hangers must be positioned so that they cannot unintentionally become rigid hangers when the system is in use. See Figure 3.8. Figure 3.9 shows a sliding piping hanger that becomes a rigid hanger with spacing in excess of 10".

3.7 Deflection

When pressing Viega MegaPress fittings in a system, the deformation of the fitting is constant. This allows for a consistent leak-free joint every time and is a result of the pressing technique.

The pressing process can cause deflection (angular misalignment) to occur. Deflection while pressing can be minimized by utilizing the below installation practices.

1. Alternating the position of the press tool on each fitting connection. An example would be placing the press tool at the 3 o'clock position of the first press connection and then alternating to the 9 o'clock position of the press fitting on the second connection.

2. If deflection occurs while pressing a MegaPress fitting, the deflection created in the piping connection will cause the fitting to move toward the hinge of the press jaw or ring being used. For MegaPress 1/2" to 1" fittings, a press jaw is used to make the press. The hinge of the press jaw is on the same side of the piping system as the press gun and operator and will therefore cause the fitting to deflect toward the press gun and operator. To help with this type of deflection, the press gun operator can slightly pull the pipe and fitting connection toward himself to create a slight bow away from the operator. As the press connection is made, the deflection will realign the piping connection back into a straight line. For 1 1/4" to 2" MegaPress fittings, a press ring along with an actuator are used to make the permanent connection. When the press ring is placed on the fitting, the hinge of the press ring is away from the installer. If deflection is to occur with this type of a press, it will cause the fitting to deflect away from the press gun and operator side of the piping system. To help with this type of deflection, the press gun operator can slightly push the pipe and fitting connection away from himself to create a slight bow toward the operator. As the press connection is made, the deflection will realign the piping connection back into a straight line. While deflection cannot be completely eliminated, it can be minimized using this method.

As long as the pipe is properly prepped and marked and the fitting is installed per MegaPress' product instructions, if there is any deflection present after the installation of the fitting, the connection is still acceptable and meets Viega's manufacturing specifications for proper installation and warranty. Deflection of a press connection has no effect on the integrity of the system and it can be pressure tested in accordance with MegaPress product instructions.

3.8 Identification

All Viega MegaPress stainless piping systems should be continuously marked in accordance with ANSI A13.1 or as required by the local authority having jurisdiction.

3.9 Viega MegaPress Stainless Steel Pipe Marking Guide Guide to the ANSI A13.1 Standard for the Identification of Pipes

Usage	Material Properties	Type of Application (typical)	Color Scheme
Hazardous Materials	<ul style="list-style-type: none"> Flammable or Explosive Chemically Active or Toxic Radioactive Extreme Temperature/Pressure 	<ul style="list-style-type: none"> Process Piping High-Pressure Steam Acids/Corrosives 	YELLOW ON BLACK
Low Hazard Materials (Liquid)	<ul style="list-style-type: none"> Liquid Liquid Admixture 	<ul style="list-style-type: none"> Cooling Water Grey Water Chilled Water 	WHITE ON GREEN
Low Hazard Materials (Gas)	<ul style="list-style-type: none"> Gas Gas Admixture 	<ul style="list-style-type: none"> Compression Air Nitrogen (N₂) Argon (Ar) 	WHITE ON BLUE
Fire Suppression	<ul style="list-style-type: none"> Liquid Gas Foam 	<ul style="list-style-type: none"> Sprinklers (Wet/Dry) CO₂ Foam (AFFF) 	WHITE ON RED

Pipe O.D. Including Covering		Minimum Length of Label Field Color		Minimum Height of Letters	
¾" to 1¼"	19 mm to 32 mm	8"	203 mm	½"	13 mm
1½" to 2"	38 mm to 51 mm	8"	203 mm	¾"	19 mm
2½" to 4"	64 mm to 108 mm	12"	305 mm	1¼"	32 mm

Marker Placement

- At all changes in directions
- At both sides of any penetrations (valves, flanges, tees, etc.)
- At frequent intervals on straight run (50 feet is typical)
- Locate pipe markers so they are readily visible
- Provide arrows indicating direction of flow

NOTE: This guide is for general information purposes only. Pipe markings shall be in accordance with local code requirements.

3.10 Viega MegaPress Stainless fitting system 1/2" to 2" installation

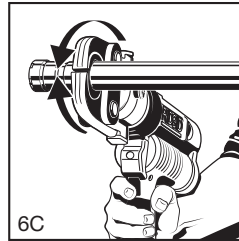
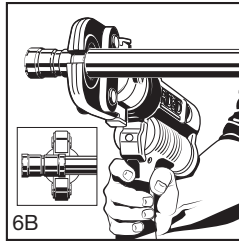
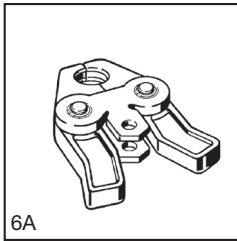
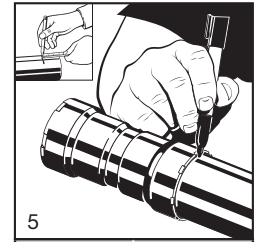
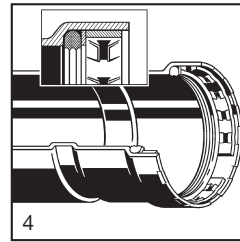
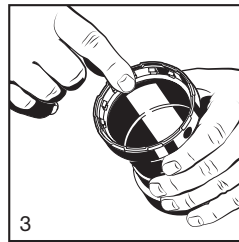
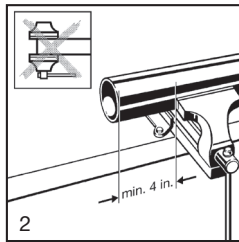
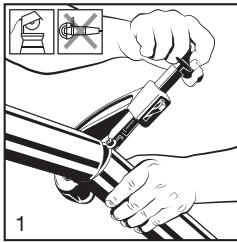

Pipe Size	Insertion Depth (in)
1/2"	1 1/16
3/4"	1 3/16
1"	1 3/8
1 1/4"	1 7/8
1 1/2"	1 7/8
2"	2

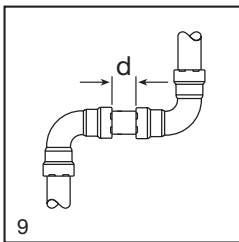
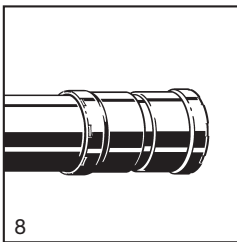
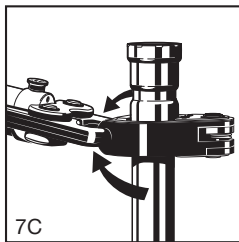
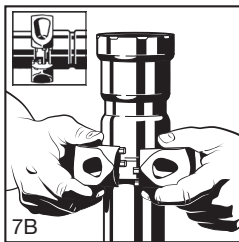
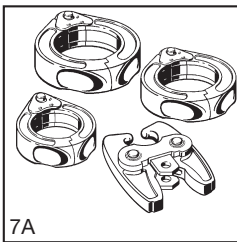

Pipe Diameter	d (in)	d (mm)
1/2"	3/16	5
3/4"	3/16	5
1"	3/16	5
1 1/4"	3/8	10
1 1/2"	3/8	10
2"	3/8	10

Viega Limited Warranty for Industrial Applications

Industrial applications are defined as non residential and non commercial applications not normally accessible to the general public, including manufacturing, mining, process or fabrication environments.

Subject to the terms and conditions of this Limited Warranty, Viega LLC (Viega) warrants to end users, installers and distribution houses that its Viega metal press products (Viega product) when properly installed in industrial applications shall be free from failure caused by manufacturing defects for a period of two (2) years from date of installation.

Under this Limited Warranty, you only have a right to a remedy if the failure or leak resulted from a manufacturing defect in the Viega product and the failure or leak occurs during the warranty period. You do not have a remedy under this warranty and the warranty remedy does not apply if the failure or any resulting damage is caused by (1) components other than those sold by Viega; (2) not designing, installing, inspecting, testing, or maintaining the Viega product in accordance with Viega's installation and product instructions in effect at the time of installation and other specifications and approvals applicable to the installation; (3) improper handling and protection of the Viega product prior to, during and after installation, inadequate freeze protection, or exposure to environmental or operating conditions not recommended for the application; or (4) acts of nature, such as, but not limited to earthquakes, fire, or weather damage. Final approval as to use compatibility to a specific process or fluid application is the responsibility of the engineer of record or responsible design/facilities personnel and this Limited Warranty only applies to manufacturing defects in the Viega Product.

In the event of a leak or other failure in the Viega product covered by this warranty, it is the responsibility of the end user to take appropriate measures to diminish any damage, to include making timely repairs. Only if the warranty applies will Viega be responsible for the remedy under this warranty. The part or parts which you claim failed should be kept and Viega contacted by writing to

the address below or telephoning 1-800-976-9819 within thirty (30) calendar days after the leak or other failure and identifying yourself as having a warranty claim. You should be prepared to ship, at your expense, the product which you claim failed due to a manufacturing defect, document the date of installation, and the amount of the repair or replacement if performed by you. Within a reasonable time after receiving the product, Viega will investigate the reasons for the failure, which includes the right to inspect the product at a Viega location and reasonable access to the site of damage. Viega will notify you in writing as to the results of its review.

In the event that Viega determines that the failure or leak was the result of a manufacturing defect in the Viega Product covered by this warranty and to which this warranty applies, the EXCLUSIVE AND ONLY REMEDY under this warranty shall be the reimbursement for reasonable charges for repair or replacement of the Viega Product itself. VIEGA SHALL NOT BE LIABLE FOR CONSEQUENTIAL OR OTHER DAMAGE (FOR EXAMPLE, ECONOMIC LOSS, WATER OR PROPERTY OR MOLD REMEDIATION) UNDER ANY LEGAL THEORY AND WHETHER ASSERTED BY DIRECT ACTION, FOR CONTRIBUTION OR INDEMNITY OR OTHERWISE.

THE ABOVE WARRANTY IS IN LIEU OF ALL OTHER WARRANTIES, EXPRESS OR IMPLIED, INCLUDING, BUT NOT LIMITED TO, THE IMPLIED WARRANTIES OR ANY STATUTE OF LIMITATIONS RELATING TO SUCH WARRANTIES. Other than this Limited Warranty, Viega does not authorize any person or firm to create for it any other obligation or liability in connection with its products.

This Limited Warranty gives you specific legal rights and you also may have other rights which may vary from state to state. This warranty shall be interpreted and applied under the law of the state in which the product is installed and is intended as a Commercial Warranty.

Viega LLC

12303 Airport Way, Ste. 395
Broomfield, CO 80021
Phone: 1-800-976-9819
Fax: 1-800-976-9817
www.viega.us

This document subject to updates. For the most current Viega technical literature please visit www.viega.us.

©2017, Viega®, ProPress®, MegaPress®, SeaPress®, PureFlow®, Smart Connect®, ManaBloc®, GeoFusion®, FostaPEX®, Radiant Wizard®, Climate Panel®, Climate Mat®, and Climate Track® are registered trademarks of Viega GmbH & Co. KG. SmartLoop® and Viega Eco Plus® are registered trademarks of Viega Holding GmbH & Co. Zero Lead™ and PolyAlloy™ are trademarks of Viega LLC. Eco Brass® is a registered trademark of Mitsubishi Shindoh Co., LTD. RIDGID® is a registered trademark of RIDGID, Inc. LoopCAD® is a registered trademark of Avenir Software Inc. Radel® is a registered trademark of Solvay Advanced Polymers, LLC.



IM-MP (Stainless) 591324 1117