

CW Series-REV. C* 2"-12"

Iron Butterfly Valve
200 psi Non-Shock WOG
For Dead End Service use CL Series
Specifications: API-609 MSS SP-67 Type 1

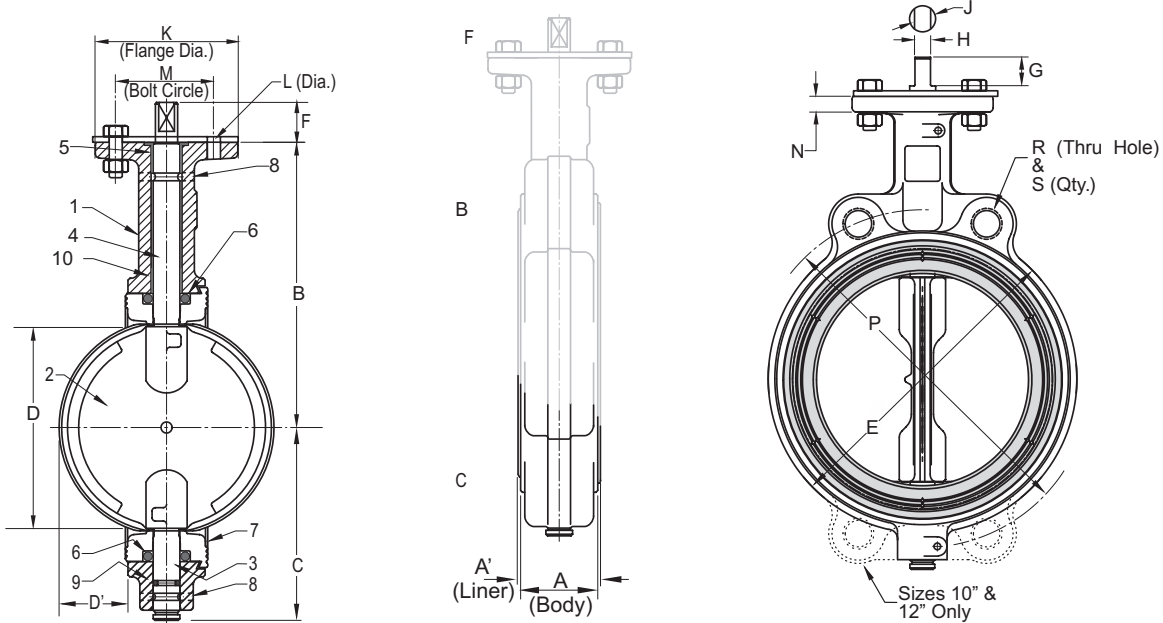

ABS Type Approved; Cat. A
 CFR-46



DIMENSIONS

MATERIALS LIST

ITEM	PART	MATERIALS
1	BODY	CAST IRON ASTM A126 CL.B
2	DISC	ALUMINUM BRONZE ASTM B148
3	BOTTOM STEM	STAINLESS STEEL TYPE 416
4	TOP STEM	STAINLESS STEEL TYPE 416
5	TOP BEARING	REINFORCED NYLON
6	SEAL	EPDM
7	LINER	EPDM
8	ROLL PIN	STAINLESS STEEL
9	STEM SEAL	EPDM
10	OPERATOR	LEVER HANDLE
		EPOXY COATED LEVER HANDLE
		GEAR OPERATOR
		GEAR OPERATOR WITH MEMORY STOP
		GEAR OPERATOR WITH LOCK

	INCHES DN	VALVE SIZE									
		2	2-1/2	3	4	5	6	8	10	12	
A (Body)	INCHES	1.69	1.81	1.81	2.07	2.19	2.19	2.38	2.69	3.06	
	mm	43	46	46	52	55	55	60	68	78	
A ¹ (Liner)	INCHES	1.82	1.94	1.94	2.20	2.32	2.32	2.51	2.82	3.21	
	mm	46	49	49	55	58	58	63	71	82	
B	INCHES	5.50	6.00	6.25	7.00	7.53	8.00	9.38	10.56	12.06	
	mm	139	152	158	177	191	203	238	268	306	
C	INCHES	3.06	3.31	3.75	4.25	4.94	5.56	5.56	7.88	9.25	
	mm	77	84	95	108	125	141	166	200	235	
D (Chord Dia)	INCHES	1.49	2.01	2.64	3.67	4.71	5.66	7.72	9.70	11.68	
	mm	37	51	67	93	119	143	196	246	296	
D ¹ (Intrusion)	INCHES	0.28	0.44	0.69	1.06	1.50	1.94	2.84	3.69	4.50	
	mm	7	11	17	27	38	49	72	93	114	
E	INCHES	4.13	4.88	5.38	6.88	7.75	8.75	11.00	13.38	16.13	
	mm	105	124	137	175	197	222	279	340	410	
F	INCHES	1.13	1.13	1.13	1.13	1.13	1.13	1.50	1.50	1.50	
	mm	28	28	28	28	28	28	38	38	38	
G	INCHES	0.81	0.81	0.81	0.81	0.81	0.81	1.06	1.06	1.06	
	mm	20	20	20	20	20	20	27	27	27	
H	INCHES	0.35	0.35	0.35	0.40	0.40	0.44	0.53	0.71	0.71	
	mm	8	8	8	10	10	11	13	18	18	
J	INCHES	0.50	0.50	0.50	0.56	0.56	0.62	0.75	1.00	1.00	
	mm	12	12	12	14	14	14	19	25	25	
K	INCHES	4	4	4	4	4	4	6	6	6	
	mm	101.6	101.6	101.6	101.6	101.6	101.6	152.4	152.4	152.4	
L (Dia)	INCHES	0.44	0.44	0.44	0.44	0.44	0.44	0.56	0.56	0.56	
	mm	11	11	11	11	11	11	14	14	14	
M	INCHES	3.25	3.25	3.25	3.25	3.25	3.25	5.00	5.00	5.00	
	mm	82	82	82	82	82	82	127	127	127	
N	INCHES	0.44	0.44	0.44	0.44	0.44	0.44	0.50	0.50	0.50	
	mm	11	11	11	11	11	11	12	12	12	
P	INCHES	4.75	5.50	6.00	7.50	8.50	9.50	11.75	14.25	17.00	
	mm	120	139	152	190	215	241	298	362	431	
R	INCHES	5/8-11	5/8-11	5/8-11	5/8-11	3/4-10	3/4-10	3/4-10	7/8-9	7/8-9	
	mm	16	16	16	16	19	19	19	19	19	
S	INCHES	2	2	2	2	2	2	2	4	4	
	mm	50.8	50.8	50.8	50.8	50.8	50.8	50.8	101.6	101.6	

***Note:** The wetted surface of this product (In any material combination.) contacted by consumable water contains less than one quarter of one percent (.25%) of lead by weight.

The information presented on this sheet is correct at the time of publication. Milwaukee Valve reserves the right to change design, and/or material specifications without notice. For the Installation, Operation and Maintenance Manual (IOM) see the Technical/Service Information section on our website. For the most current information access www.milwaukeevalve.com



C	L	2	2	3	E
VALVE SERIES	BODY STYLE	OPERATOR	BODY MATERIAL	DISC MATERIAL	LINER MATERIAL
C - C SERIES	L - LUG BODY W - WAFFER BODY	1 - VALVE ONLY 2 - LEVER HANDLE 3 - GEAR OPERATOR	2 - CAST IRON*	3 - ALUMINUM/BRONZE	E - EPDM

* MILWAUKEE VALVE RESERVES THE
RIGHT TO UPGRADE TO DI BODY
WITHOUT NOTICE FOR NO ADDITIONAL
COST.