

Viega ProPress for Stainless System



The global leader
in plumbing, heating
and pipe joining systems

viega



1899

1901

Viega adds traps and draining products for sinks and bathtubs to our lineup.



1935

The first PEX radiant floor heating in the U.S., the Viega ProRadiant system, is introduced.



1963

1980

The Viega MANABLOC water distribution manifold is introduced.

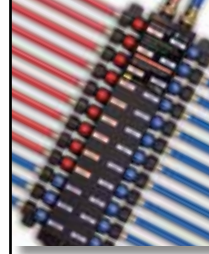

1988

1989

Viega launches the Viega ProPress marine system.



1996



Franz-Anselm Viegener starts Viega Co. with first brass beer tap.



Viega starts manufacturing plumbing fittings.



Viega starts producing copper solder fittings.



Viega's press technology begins in Germany.

A heritage of better ideas since 1899

Our heritage of innovation and quality began in Attendorn, Germany, in 1899 when Franz-Anselm Viegener introduced a new design in brass beer taps. By 1901, the company evolved and began

manufacturing home plumbing products. But our story, the North American story, really began in 1999, when the family-owned Viega decided to offer a selection of Viega products in the United States.

Initial product offerings in the United States consisted of PEX radiant floor heating systems. Soon after, we continued to expand our U.S. product

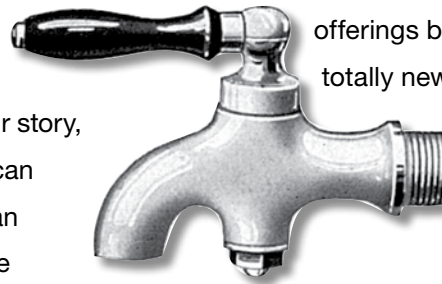

offerings by introducing a totally new system of Viega ProPress fittings and valves to connect copper pipe. The new century saw rapid growth

in Viega innovations, including Viega PureFlow — the first PEX press plumbing technology, Viega ProPressG for solderless fuel gas applications, hybrid technology to connect copper to PEX and the Smart Connect feature to quickly identify unpressed fittings.

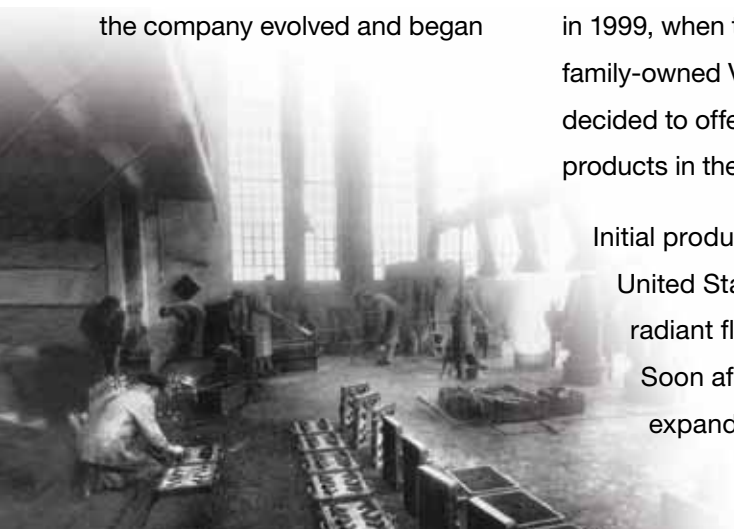

Viega's copper press technology launches in the U.S., the Viega ProPress system.



Viega creates hybrid technology to connect copper to PEX.



Viega stainless press technology launches in the U.S., Viega ProPress for stainless.



Viega launches the Viega Poly PEX Press system.



1996

1999

2000

2005

2008

2011

2012



Production of plastic tubing, Viega PureFlow PEX products begins.



Viega introduces the first Viega PEX Press plumbing technology in North America.



Viega has four Distribution Centers in the U.S.:
Reno, NV (2006);
McPherson, KS (2009);
Atlanta, GA (2011);
Harrisburg, PA (2011).



Viega launches the Viega MegaPress system in the U.S.

As a pioneer in the industry, Viega has provided the best solutions possible. In keeping with our tradition of excellence, Viega introduced its first stainless system in 1989 and has been revolutionizing applications ever since. With Viega ProPress for stainless, industrial and commercial installations can be completed with little to no downtime. Available in two high-quality grades of stainless steel, 304 and 316, Viega ProPress for stainless is perfectly suited for

any application. Viega ProPress for stainless 316 meets 2011 low-lead legislation. Even commercial applications can enjoy the security and reliability of Viega press technology.

With the construction of our 439,000-square-foot distribution facility in McPherson, KS, in 2009, Viega is now able to supply our products to more people more efficiently than ever.



From Franz-Anselm Viegener's first product introduction in 1899, Viega's family heritage of innovation, quality and service still flows through all of our products and the people who design, make, sell and support them. It is our heritage of better ideas that allows us to extend our reach to exceed customer expectations around the globe.



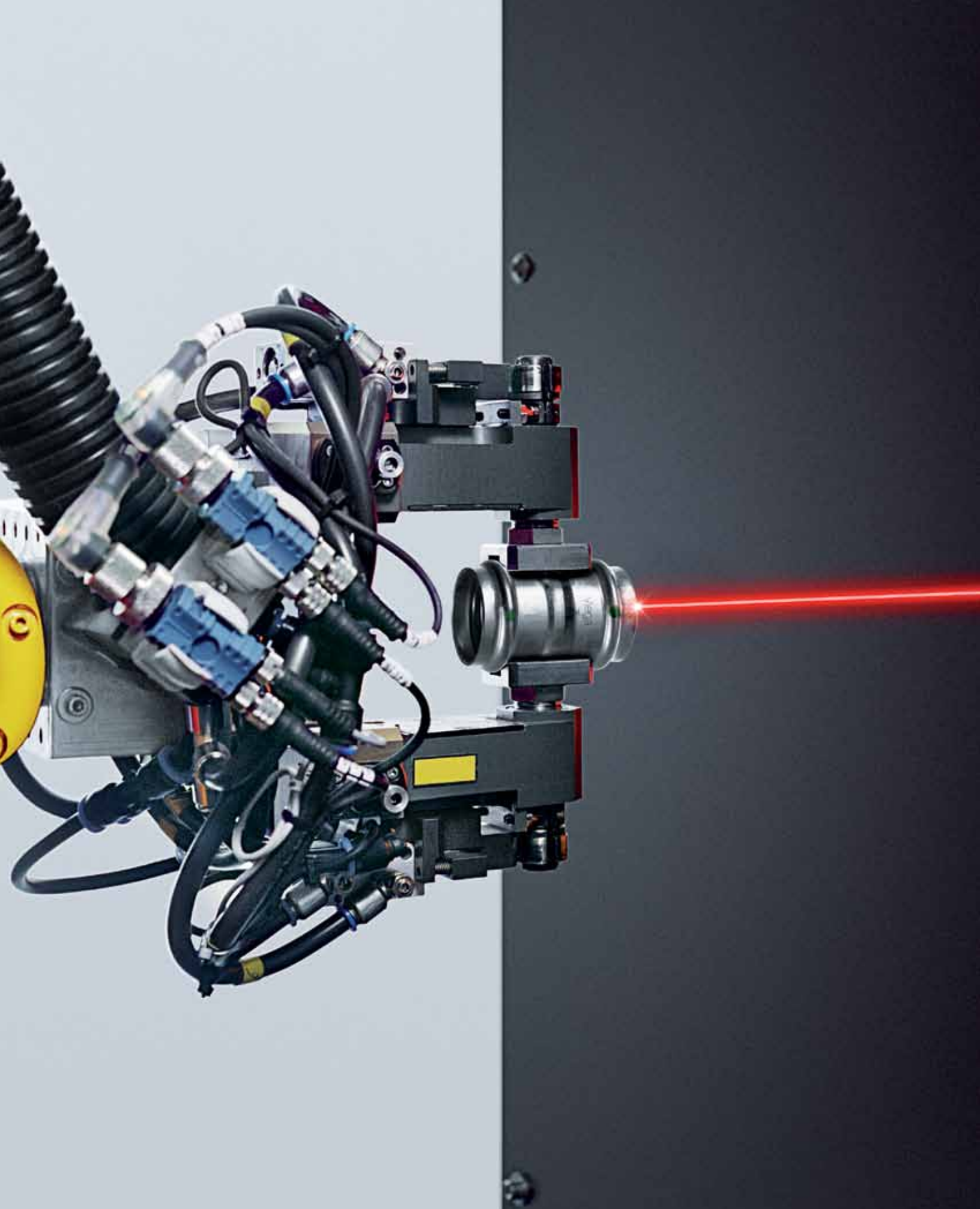

Viega, the global leader in flameless technology, is now stainless.

Viega products set the industry standard for press fit technology by providing millions of connections for commercial, residential and industrial buildings. Available in two high-quality stainless grades, 304 and 316, Viega combines reliability and speed to complete any project quickly and efficiently while reducing costly downtime. Available in a wide variety of configurations, sizes and materials, Viega has the solution for any plumbing, heating or pipe joining installation or application.

Variety and competence

Viega's portfolio includes more than 16,000 products offered worldwide, which not only represents a unique selection for the industry but also demonstrates a legacy of exceptional quality. Excellently trained employees, superior raw materials and highly modernized production sites work together to manufacture the best plumbing, heating and pipe joining products in the world. Beyond producing extraordinary products, however, Viega also seeks to educate customers through unparalleled support in training and design services at our state-of-the-art Educational Facility.

Efficiency and precision

Viega's integrated distribution system makes it possible for us to process your order in 24 hours or less. The innovative logistics concept within our four distribution centers across the United States allows us to get our products to our customers faster than our competition. As the industry leader in pipe joining technology, Viega delivers value with the speed and accuracy customers have the right to expect.



Safety is designed into every fitting for your peace of mind

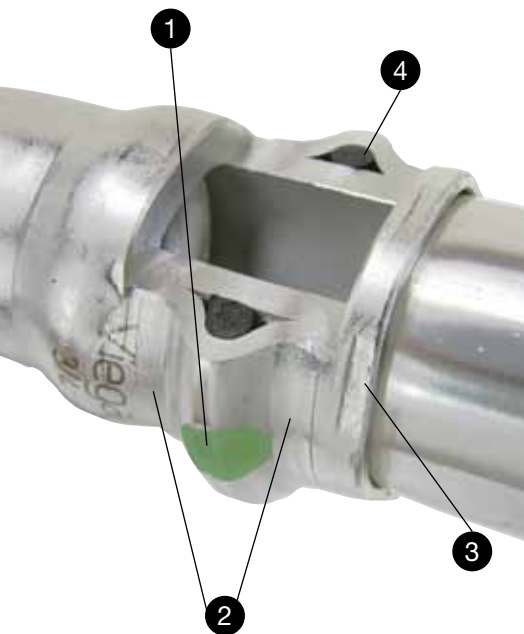

At Viega, safety is priority.

- 1** Viega's unique, patented Smart Connect feature helps installers ensure that they have pressed all connections.
- 2** Viega fittings offer integral cylindrical pipe guides which help installers ensure that the fitting is correctly inserted on the pipe.
- 3** Viega's distinctive hexagonal pressing pattern bonds fitting and pipe and provides the mechanical strength for the connection.
- 4** Viega offers three different sealing elements to suit virtually any application: EPDM, HNBR and FKM.

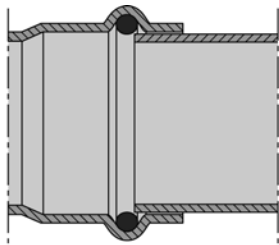

All Viega ProPress fittings are designed with cylindrical pipe guides (2) to keep the pipe straight and protect the sealing element during assembly.

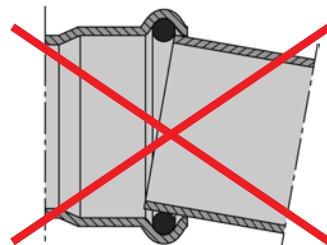

Fittings that do not have cylindrical pipe guides risk making an unsecure connection and leave the sealing element vulnerable.

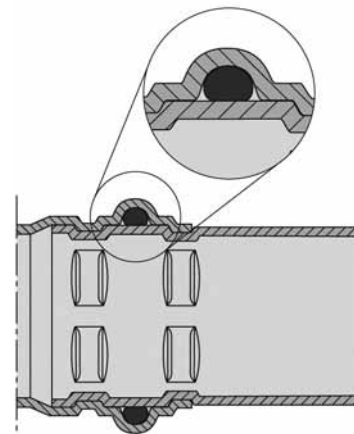

Viega fittings are pressed before, after and on top of the sealing element (3) in a single step, which creates a permanent connection that is secure and guaranteed to last.



Security under pressure

When pressure testing a system after all fittings have been installed, Viega recommends a step test to ensure that all connections have been pressed. Testing the system at full pressure initially may result in a false positive reading. By testing at a lower pressure first, Viega's patented Smart Connect feature will identify which fittings have not been pressed. Viega recommends the Smart Connect feature be tested at 15 to 85 psi when testing with water or 0.5 to 85 psi when testing with air. After ensuring that all connections have been correctly pressed, installers may increase the test pressure to full system test requirements.



Viega ProPress 304 and 316

Two grades of stainless steel ...
One joining system.



- Complete system solution – pipe, valves and fittings
- Sizes – 1/2" to 4"
- Specialty fittings for instrumentation
- Sealing elements to meet application needs – EPDM, HNBR and FKM

- Orange identifies Viega ProPress for stainless steel 304
- Green identifies Viega ProPress for stainless steel 316
- White identifies the FKM sealing element (304/316)

Applications

Contact Viega for parameters, selections of grade of stainless and sealing element choice.

- | | | |
|------------------|-------------------|-------------------|
| • Additives | • Caustic | • Cooling Water |
| • Sludge | • Paint Lines | • Process Air |
| • Aeration | • Starch | • Waste Water |
| • Lube Oil | • Chilled Water | • DI Water |
| • Slurry | • Plant Air | • Process Waste |
| • Compressed Air | • Stock | • Dye |
| • Mill Water | • Plant Water | • Process Water |
| • Soda Ash | • UREA | • R/O Water |
| • Black Liquor | • Condenser Water | • Filter Water |
| • Nitrogen | • Potable Water | • Pump Seal Water |
| • Spray Water | • Vacuum | • Green Liquor |

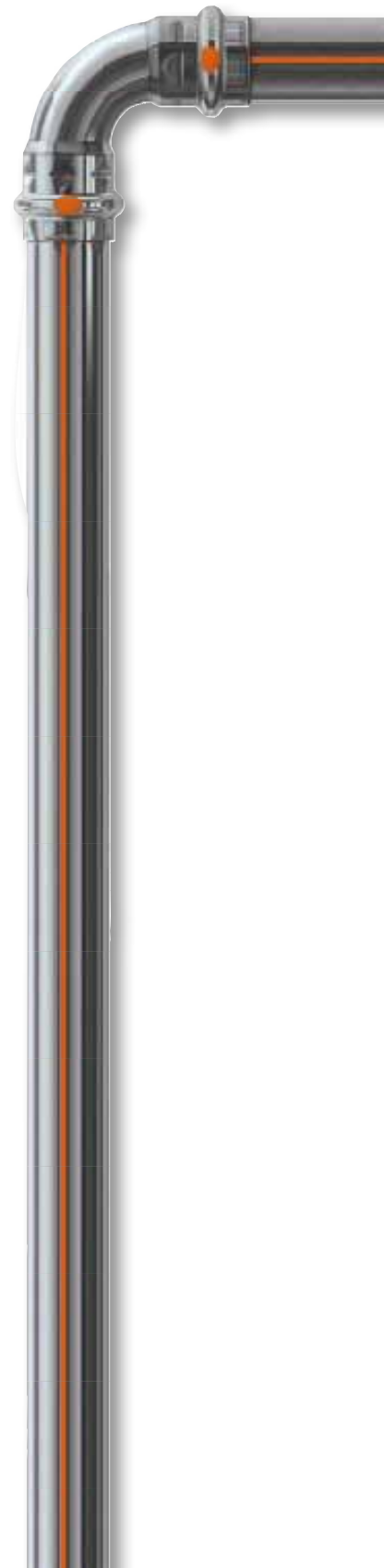



Press technology ... The inside story.

Viega ProPress for stainless 1/2" to 2" fittings

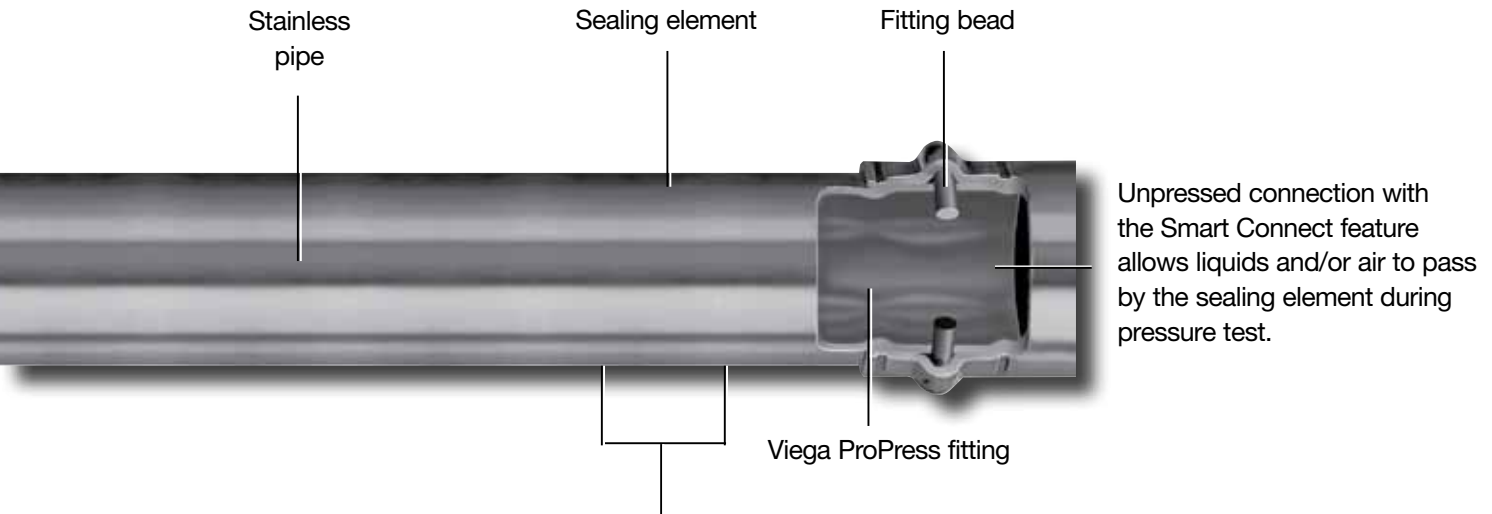

Connection is pressed in front of, on top of, and behind the seal, making a gas and water tight seal. The Smart Connect feature is sealed during pressing.

Viega ProPress XL-S for stainless 2-1/2" to 4" fittings

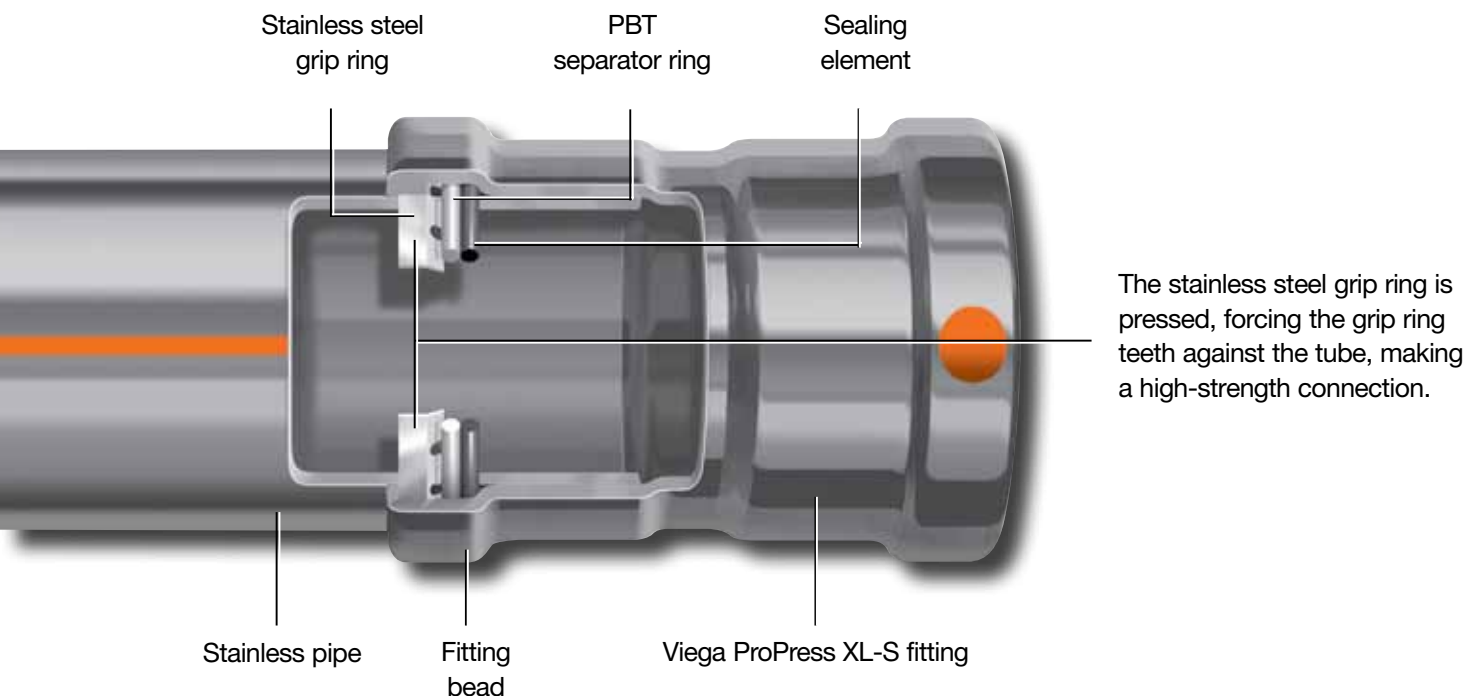

Table of Contents

viega

System Data	11
Viega Sealing Elements	12
Viega Flange Gasket	13
Viega Grip and Separator Ring	13
Dimensional Documentation –	
Viega ProPress for stainless 1/2" to 2"	14
Viega ProPress for stainless XL-S 2-1/2" to 4" ...	25
Engineering Data	32
Engineering Specifications	39
Product Instruction –	
1/2" to 2"	41
2-1/2" to 4"	42
Stainless Galvanic Corrosion Prevention	43
Special Products –	
Viega ProPress for stainless XL-S Cross	44
Viega ProPress for stainless Di-Electric Union - Female	45
Viega ProPress 304 & 316 for stainless steel Transition Fittings	46
Raised Face Adapter Flange	47
Instrumentation Adapters	48
Product Specification –	
Viega ProPress for 316 stainless steel Ball Valve	49
Frequently Asked Questions	50

System Data

System Description

Viega ProPress for stainless and Viega ProPress for stainless XL-S are safe, reliable and economical stainless steel pipe installation systems that use modern cold press connection technology for a wide assortment of fittings and pipe, in dimensions ranging from 1/2" to 4".

Operating Parameters

- Operating pressure 200 PSI
- Test pressure 600 PSI max.
- Low pressure steam 15 PSI max.
- Vacuum 29.2" mercury max. @ 68°F
- Operating temperature 0°F - 250°F
- FKM max. temp = 284°F
- Please consult Viega on parameters, selection of grade of stainless and sealing element choice

Approved Applications

Refer to Viega's Tech Bulletins for approved applications and chemical compatibility.

System Benefits

- Flameless, fast and easy to use
- Permanent reliable connections
- Wide capacity from 1/2" to 4"
- Large selection of fittings
- Consistent professional appearance
- Less equipment required
- Environmentally friendly connection system
- Versatility of fittings and tools for a variety of applications

Fittings

Viega ProPress for stainless and Viega ProPress for stainless XL-S fittings are offered in over 350 configurations of 304 stainless steel and 316 stainless steel, including: Elbows, Couplings, Ball Valves, Reducers, Tees, Reducing Tees, Threaded Adapters, Unions, Caps and Flanges. **Viega ProPress for stainless and Viega ProPress for stainless XL-S fittings are designed to be used with only Viega ProPress for stainless steel pipe.**

Fitting Markings

Each fitting is marked with the following:

- Viega
- The fitting dimension
- Production batch code
- Material (304 or 316)

Pipe

Viega ProPress for stainless steel pipe is offered in either 304 stainless or 316 stainless to compliment the Viega fittings and offer a complete system solution. Viega ProPress for stainless steel pipe meets the requirement of ASTM A312 or ASTM A554 for schedule 5 304 and 316 stainless steel pipe.

Smart Connect

In Viega ProPress for stainless 1/2" to 4" dimensions, the Smart Connect feature assures leakage of liquids and/or gases from inside the system past the sealing element of an unpressed connection. The function of this feature is to provide the installer quick and easy identification of connections which have not been pressed prior to putting the system into operation.

History

Viega ProPress has been used in Europe since the late 1980's and in the U.S. since the late 1990's for a variety of applications.

Warranty

Viega ProPress for stainless products carry a 2-year warranty against defects in material and workmanship. The RIDGID Lifetime Warranty applies to tools, jaws and press rings from Ridge Tool Company.

Approvals and Certificates for North America



ASTM A240 ASTM A554
ASTM A312
ASTM A403



ASME B31.1
ASME B31.3
ASME B31.9



American Bureau
of Shipping



NSF-61 Annex-G
'Zero-Lead' Components
NSF-61 HW for Ball Valves



CRN- Canadian Registration
Number - 13492.5



Ball valves for
Potable Water

International Approvals

- ABS
- TSSA

Compliant with

- ICC International Plumbing Code
- SBCCI International Standard Plumbing Code
- UPC Uniform Plumbing Code
- BOCA National Plumbing Code 199
- PHCC National Standard Plumbing Code
- Florida Bilding Code, Volume II Plumbing Code

Contact your local Viega representative for details on local approvals.

Tools

RIDGID offers press tools for connecting the Viega ProPress Systems, stainless and copper.

For more information on RIDGID products contact:

Ridge Tool Company
400 Clark Street, Elyria OH 44036

Demos and Literature:
800-769-7743

Technical Inquiries:
800-519-3456

Availability:
888-743-4333

On the web: www.ridgid.com

MTR - available through Viega web site

Viega Sealing Elements

EPDM Sealing Element

Operating temperature:

0°F to 250°F (-18°C to 120°C)

Viega Press Systems press fittings are manufactured with a high quality EPDM sealing element installed at the factory.

This sealing element is used mainly in the applications of potable water, hydronic heating, low-pressure steam, fire sprinkler, and compressed air installations. EPDM, or ethylene-propylene-dienemonomer, is gloss black in color.

The EPDM sealing element is a synthetically manufactured and peroxidically cross-linked general purpose elastomer with a wide range of applications.

FKM Sealing Element

Operating temperature:

0°F to 284°F (-18°C to 140°C)

Resistant to heat spikes to 356°F
FKM's excellent resistance to high temperatures and petroleum based additives makes it ideal for seals and gaskets in solar, district heating, low pressure steam, and compressed air system fittings.

FKM (Fluoroelastomer) is flat black in color. It possesses excellent resistance to aging against hot temperatures.

HNBR Sealing Element

Operating temperature:

-40°F to 180°F (-40°C to 82°C)

HNBR sealing element is used mainly for applications of natural, propane, mixed, and manufactured gases in the vapor state (not in the liquid state).

It is commonly used in fuel oil heating systems. HNBR, or Hydrogenated Nitrile Butadiene Rubber, is yellow in color.

The unique properties attributed to HNBR have resulted in wide adoption of HNBR in automotive, industrial, and assorted high performance applications (i.e. Engine seals, grommets, and gaskets; Fuel system seals and hoses; Transmission system bonded piston seals; Oil field packers, and rotary shaft seals).

Sealing Elements Temperature Range

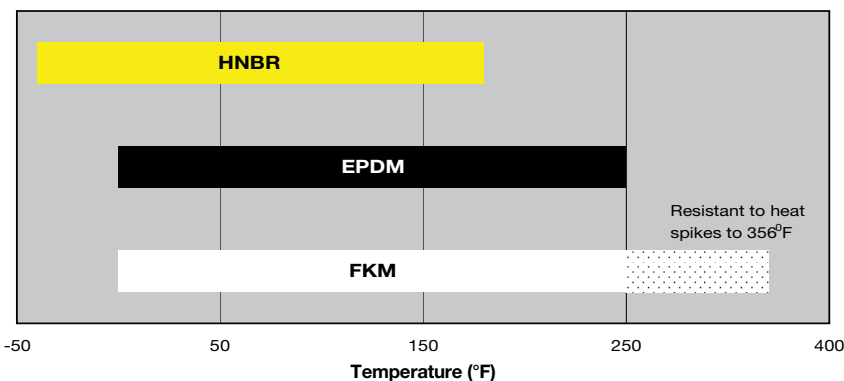

All sealing elements are inserted into the fitting using a #1 food grade lubricant registered with NSF, the USDA and approved for use under FDA 21 CFR.

Viega Flange Gasket

Viega Flange gaskets are an asbestos-free gasket material composed of aramid fibers, inorganic fillers and other asbestos substitutes which are resistant to high temperatures.

These are firmly bonded to high grade elastomers under elevated pressure and temperature. The gaskets do not contain any color pigments.

The material exhibits high tensile strength, stress as well as shearing resistance. Other characteristic properties of the material are excellent temperature resistance, stress resistance under high operating pressure and ease of handling.

The gasket material has a non-stick top and bottom layer with a high coefficient of friction. This aids in dismantling. Additional surface treatment is not needed in most cases.

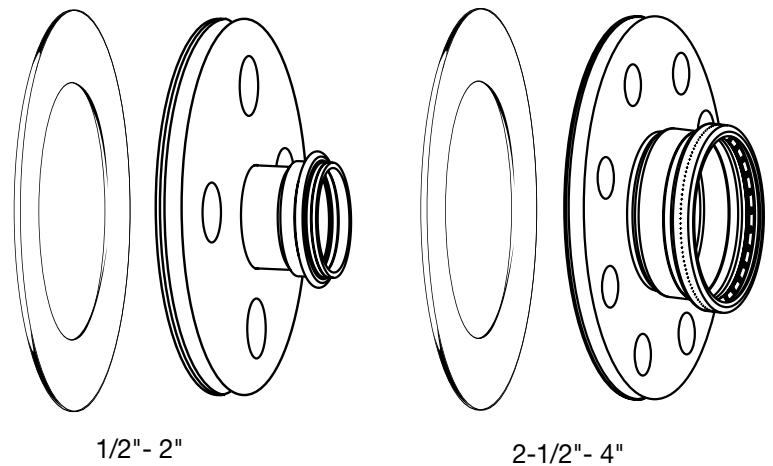

Viega Grip and Separator Ring

The grip ring is made of 420 (1.4021) stainless steel. The grip ring ensures the XL-S fittings create a positive cold press mechanical joint. The PBT (Polybutylene Terephthalate) separator ring ensures that sealing element and grip ring perform at maximum capacity by providing a positive physical separation.

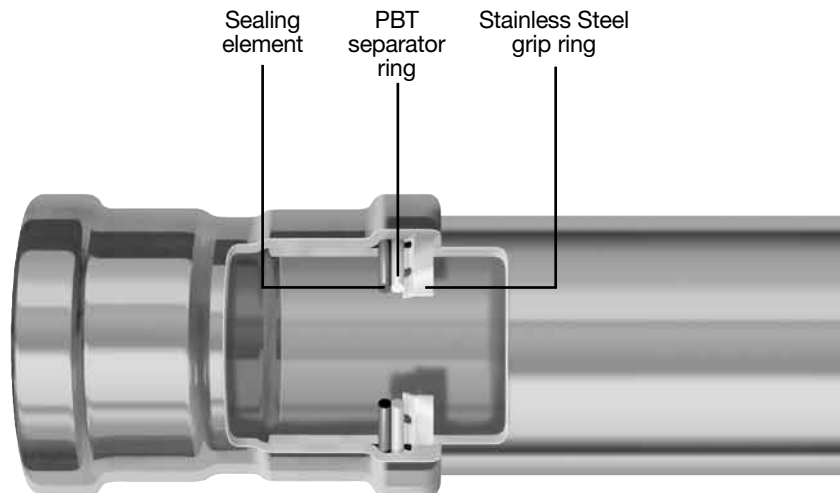

Dimensional Documentation

Viega ProPress for stainless 1/2" - 2"

Viega ProPress for stainless steel 304 ECO-Pipe ASTM A554 Model - 0108

Catalog No.	Size	O.D. (in)	I.D. (in)	Wall Thickness	Length (ft)
87050	1/2"	0.63	0.55	0.04	20
87055	3/4"	0.88	0.78	0.05	20
87060	1"	1.13	1.04	0.05	20
87065	1-1/4"	1.38	1.27	0.06	20
87070	1-1/2"	1.63	1.52	0.06	20
87075	2"	2.13	2.02	0.06	20

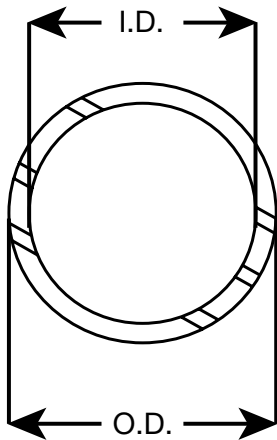

Viega ProPress for stainless steel 304 & 316 Pipe ASTM A312 Model - 0103 / 4003

Catalog No.		Size	O.D. (in)	I.D. (in)	Wall Thickness	Length (ft)
S/S 304	S/S 316					
87000	82000	1/2"	0.63	0.49	0.07	20
87005	82005	3/4"	0.88	0.77	0.07	20
87010	82010	1"	1.13	0.99	0.07	20
87015	82015	1-1/4"	1.38	1.24	0.07	20
87020	82020	1-1/2"	1.63	1.49	0.07	20
87025	82025	2"	2.13	1.99	0.07	20

Adapter P x M NPT w/ EPDM Seals Model - 0111 / 4011

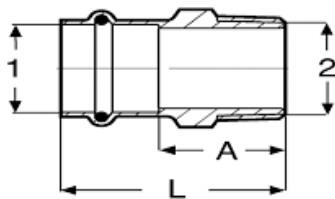

Catalog No.		Size	A (in)	L (in)
S/S 304	S/S 316	1 2		
85010	80010	1/2" x 1/2" NPT	1.260	2.010
85015	80015	1/2" x 3/4" NPT	1.339	2.090
85020	80020	3/4" x 1/2" NPT	1.398	2.300
85025	80025	3/4" x 3/4" NPT	1.437	2.340
85030	80030	3/4" x 1" NPT	1.693	2.600
85035	80035	1" x 3/4" NPT	1.457	2.360
85040	80040	1" x 1" NPT	1.732	2.640
85045	80045	1-1/4" x 1-1/4" NPT	1.880	2.910
85050	80050	1-1/2" x 1-1/2" NPT	1.949	3.370
85055	80055	2" x 2" NPT	2.106	3.680

Dimensional Documentation

Adapter P x M NPT w/ FKM Seals Model - 6011

Catalog No.	Size		A (in)	L (in)
	S/S 304	1 2		
85012		1/2" x 1/2" NPT	1.260	2.010
85017		1/2" x 3/4" NPT	1.339	2.090
85022		3/4" x 1/2" NPT	1.398	2.300
85027		3/4" x 3/4" NPT	1.437	2.340
85032		3/4" x 1" NPT	1.693	2.600
85037		1" x 3/4" NPT	1.457	2.360
85042		1" x 1" NPT	1.732	2.640
85047		1-1/4" x 1-1/4" NPT	1.880	2.910
85052		1-1/2" x 1-1/2" NPT	1.949	3.370
85057		2" x 2" NPT	2.106	3.680

Adapter P x F NPT w/ EPDM Seals Model - 0112 / 4012

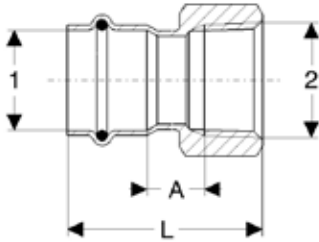

Catalog No.		Size		A (in)	L (in)
S/S 304	S/S 316	1	2		
85080	80080	1/2" x 1/2" NPT		1.024	1.772
85085	80085	3/4" x 1/2" NPT		1.240	2.146
85090	80090	3/4" x 3/4" NPT		1.181	2.087
85092	80092	1" x 1/2" NPT		1.161	2.067
85095	80095	1" x 3/4" NPT		1.240	2.146
85100	80100	1" x 1" NPT		1.299	2.205
85105	80105	1-1/4" x 1-1/4" NPT		1.329	2.362
85110	80110	1-1/2" x 1-1/4" NPT		1.407	2.835
85115	80115	1-1/2" x 1-1/2" NPT		1.407	2.835
85075	80075	2" x 1" NPT		1.604	3.189
85120	80120	2" x 1-1/2" NPT		1.447	3.031
85125	80125	2" x 2" NPT		1.489	3.071

Adapter P x F NPT w/ FKM Seals Model - 6012

Catalog No.	Size		A (in)	L (in)
	S/S 304	1 2		
85082		1/2" x 1/2" NPT	1.024	1.772
85087		3/4" x 1/2" NPT	1.240	2.146
85096		3/4" x 3/4" NPT	1.181	2.087
85094		1" x 1/2" NPT	1.161	2.067
85097		1" x 3/4" NPT	1.240	2.146
85102		1" x 1" NPT	1.299	2.205
85107		1-1/4" x 1-1/4" NPT	1.329	2.362
85117		1-1/2" x 1-1/2" NPT	1.407	2.835
85077		2" x 1" NPT	1.604	3.189
85122		2" x 1-1/2" NPT	1.447	3.031
85127		2" x 2" NPT	1.489	3.071

Dimensional Documentation

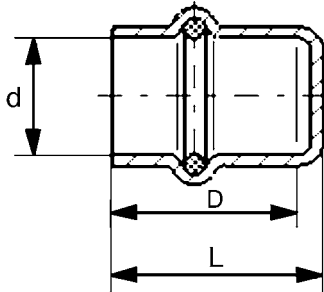

Cap P w/ EPDM Seals Model - 0156 / 4056

Catalog No.		Size	L	D
S/S 304	S/S 316	1	(in)	(in)
85355	80355	1/2"	0.819	0.693
85360	80360	3/4"	1.043	0.925
85365	80365	1"	1.063	0.945
85370	80370	1-1/4"	1.200	1.043
85375	80375	1-1/2"	1.594	1.435
85380	80380	2"	1.744	1.585

Cap P w/ FKM Seals Model - 6056

Catalog No.		Size	L	D
S/S 304		1	(in)	(in)
85357		1/2"	0.819	0.693
85362		3/4"	1.043	0.925
85367		1"	1.063	0.945
85372		1-1/4"	1.200	1.043
85377		1-1/2"	1.594	1.435
85382		2"	1.744	1.585

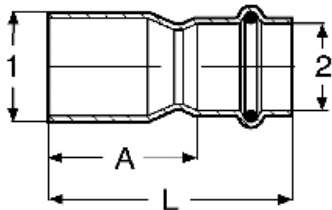

Reducer FTG x P w/ EPDM Seals Model - 01151 / 40151

Catalog No.		Size	A	L
S/S 304	S/S 316	1 2	(in)	(in)
85160	80160	3/4" x 1/2"	1.535	2.283
85165	80165	1" x 1/2"	1.831	2.579
85170	80170	1" x 3/4"	1.555	2.461
85175	80175	1-1/4" x 1/2"	2.244	2.992
85180	80180	1-1/4" x 3/4"	1.929	2.835
85185	80185	1-1/4" x 1"	1.811	2.717
85190	80190	1-1/2" x 1/2"	3.051	3.799
85195	80195	1-1/2" x 3/4"	2.618	3.524
85200	80200	1-1/2" x 1"	2.500	3.406
85205	80205	1-1/2" x 1-1/4"	2.256	3.287
85210	80210	2" x 1/2"	3.740	4.488
85215	80215	2" x 3/4"	3.465	4.370
85220	80220	2" x 1"	3.091	3.996
85225	80225	2" x 1-1/4"	2.827	3.858
85230	80230	2" x 1-1/2"	2.598	4.016

Dimensional Documentation

Reducer FTG x P w/ FKM Seals Model - 6015.1

Catalog No.	Size	A	L
S/S 304	1 2	(in)	(in)
85162	3/4" x 1/2"	1.535	2.283
85167	1" x 1/2"	1.831	2.579
85172	1" x 3/4"	1.555	2.461
85177	1-1/4" x 1/2"	2.244	2.992
85182	1-1/4" x 3/4"	1.929	2.835
85187	1-1/4" x 1"	1.811	2.717
85192	1-1/2" x 1/2"	3.051	3.799
85197	1-1/2" x 3/4"	2.618	3.524
85202	1-1/2" x 1"	2.500	3.406
85212	2" x 1/2"	3.740	4.488
85217	2" x 3/4"	3.465	4.370
85222	2" x 1"	3.091	3.996
85232	2" x 1-1/2"	2.598	4.016

Union P x P w/ EPDM Seals Model - 0160 / 4060

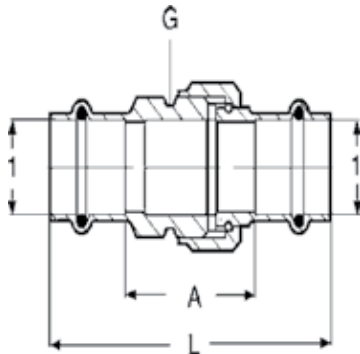

Catalog No.	Size	A	L	G	
S/S 304	S/S 316	1	(in)	(in)	
86005	81005	1/2"	1.858	3.354	3/4"
86010	81010	3/4"	1.850	3.661	1"
86015	81015	1"	2.224	4.035	1-1/4"
86020	81020	1-1/4"	2.224	4.291	1-1/2"
86025	81025	1-1/2"	2.677	5.531	2"
86030	81030	2"	2.953	6.122	2-1/2"

Union P x P w/ FKM Seals Model - 6060

Catalog No.	Size	A	L	G
S/S 304	1	(in)	(in)	
86007	1/2"	1.858	3.354	3/4"
86012	3/4"	1.850	3.661	1"
86017	1"	2.224	4.035	1-1/4"
86022	1-1/4"	2.224	4.291	1-1/2"
86027	1-1/2"	2.677	5.531	2"
86032	2"	2.953	6.122	2-1/2"

Dimensional Documentation

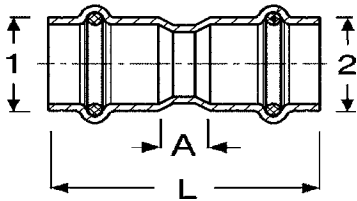

Coupling P x P w/ Stop w/ EPDM Seals Model - 0115 / 4015

Catalog No.		Size	A	L
S/S 304	S/S 316	1	(in)	(in)
85265	80265	1/2"	0.354	1.850
85270	80270	3/4"	0.433	2.244
85275	80275	1"	0.374	2.185
85280	80280	1-1/4"	0.461	2.528
85285	80285	1-1/2"	0.335	3.189
85290	80290	2"	0.453	3.642

Coupling P x P w/ Stop w/ FKM Seals Model - 6015

Catalog No.		Size	A	L
S/S 304	S/S 316	1	(in)	(in)
85267	80267	1/2"	0.354	1.850
85272	80272	3/4"	0.433	2.244
85277	80277	1"	0.374	2.185
85282	80282	1-1/4"	0.461	2.528
85287	80287	1-1/2"	0.335	3.189
85292	80292	2"	0.453	3.642

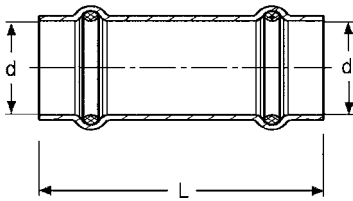

Slip Coupling P x P w/ EPDM Seals Model - 01155 / 40155

Catalog No.		Size	L
S/S 304	S/S 316	1	(in)
85310	80310	1/2"	1.850
85315	80315	3/4"	2.272
85320	80320	1"	2.185
85325	80325	1-1/4"	2.520
85330	80330	1-1/2"	3.189
85335	80335	2"	3.642

Slip Coupling P x P w/ FKM Seals Model - 6015.5

Catalog No.		Size	L
S/S 304	S/S 316	1	(in)
85312	80312	1/2"	1.850
85317	80317	3/4"	2.272
85322	80322	1"	2.185
85327	80327	1-1/4"	2.520
85332	80332	1-1/2"	3.189
85337	80337	2"	3.642

Dimensional Documentation

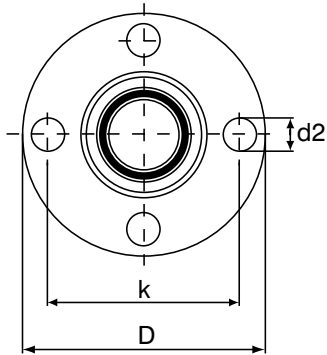
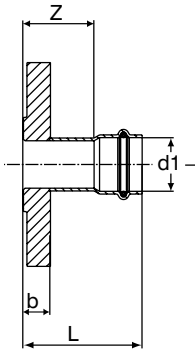

Flange P x Flange w/ EPDM Seals Model - 0159 / 4059

Catalog No.		Size	L	Z	b	d2	D	k
S/S 304	S/S 316	1	(in)	(in)	(in)	(in)	(in)	(in)
86035	81035	1/2"	2.465	1.717	0.457	0.630	3.543	2.348
86040	81040	3/4"	2.587	1.681	0.520	0.630	3.937	2.756
86045	81045	1"	2.528	1.622	0.579	0.630	4.331	3.110
86050	81050	1-1/4"	2.709	1.675	0.642	0.630	4.528	3.504
86055	81055	1-1/2"	2.850	1.423	0.705	0.630	4.921	3.858
86060	81060	2"	3.878	2.293	0.768	0.748	5.906	4.764

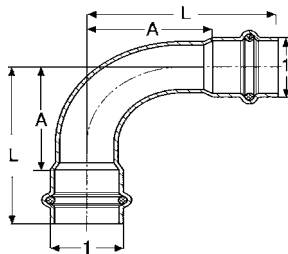

Elbow 90° P x P w/ EPDM Seals Model - 0116 / 4016

Catalog No.		Size	A	L
S/S 304	S/S 316	1	(in)	(in)
85400	80400	1/2"	1.122	1.870
85405	80405	3/4"	1.732	2.638
85410	80410	1"	1.323	2.228
85415	80415	1-1/4"	1.654	2.687
85420	80420	1-1/2"	1.984	3.413
85425	80425	2"	2.551	4.138

Elbow 90° P x P w/ FKM Seals Model - 6016

Catalog No.		Size	A	L
S/S 304		1	(in)	(in)
85402		1/2"	1.122	1.870
85407		3/4"	1.732	2.638
85412		1"	1.323	2.228
85417		1-1/4"	1.654	2.687
85422		1-1/2"	1.984	3.413
85427		2"	2.551	4.138

Dimensional Documentation

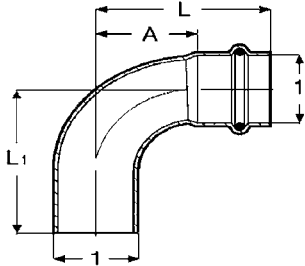

Elbow 90° FTG x P w/ EPDM Seals Model - 01161 / 40161

Catalog No.		Size	A	L	L1
S/S 304	S/S 316	1	(in)	(in)	(in)
85490	80490	1/2"	1.122	1.870	1.988
85495	80495	3/4"	1.449	2.354	3.031
85500	80500	1"	1.323	2.228	2.268
85505	80505	1-1/4"	1.654	2.689	2.756
85510	80510	1-1/2"	1.984	3.413	3.480
85515	80515	2"	2.551	4.138	4.205

Elbow 90° FTG x P w/ FKM Seals Model - 6016.1

Catalog No.		Size	A	L	L1
S/S 304		1	(in)	(in)	(in)
85492		1/2"	1.122	1.870	1.988
85497		3/4"	1.449	2.354	3.031
85502		1"	1.323	2.228	2.268
85512		1-1/2"	1.984	3.413	3.480
85517		2"	2.551	4.138	4.205

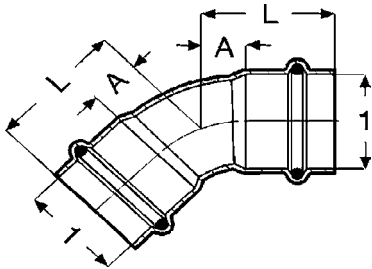

Elbow 45° P x P w/ EPDM Seals Model - 0126 / 4026

Catalog No.		Size	A	L
S/S 304	S/S 316	1	(in)	(in)
85445	80445	1/2"	0.571	1.319
85450	80450	3/4"	0.866	1.772
85455	80455	1"	0.547	1.453
85460	80460	1-1/4"	0.685	1.717
85465	80465	1-1/2"	0.823	2.248
85470	80470	2"	1.055	2.642

Elbow 45° P x P w/ EPDM Seals Model - 6026

Catalog No.		Size	A	L
S/S 304		1	(in)	(in)
85447		1/2"	0.571	1.319
85452		3/4"	0.866	1.772
85457		1"	0.547	1.453
85462		1-1/4"	0.685	1.717
85467		1-1/2"	0.823	2.248
85472		2"	1.055	2.642

Dimensional Documentation

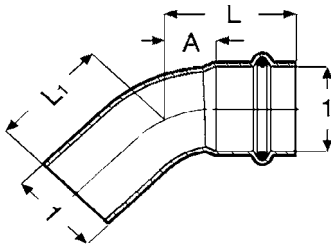

Elbow 45° FTG x P w/ EPDM Seals Model - 01261 / 40261

Catalog No.		Size	A	L	L1
S/S 304	S/S 316	1	(in)	(in)	(in)
85535	80535	1/2"	0.571	1.319	1.457
85540	80540	3/4"	0.685	1.591	2.272
85545	80545	1"	0.547	1.453	1.492
85550	80550	1-1/4"	0.685	1.717	1.787
85555	80555	1-1/2"	0.822	2.248	2.319
85560	80560	2"	1.055	2.642	2.709

Elbow 45° FTG x P w/ FKM Seals Model - 6026.1

Catalog No.		Size	A	L	L1
S/S 304	S/S 316	1	(in)	(in)	(in)
85537	80537	1/2"	0.571	1.319	1.457
85542	80542	3/4"	0.685	1.591	2.272
85547	80547	1"	0.547	1.453	1.492
85557	80557	1-1/2"	0.822	2.248	2.319
85562	80562	2"	1.055	2.642	2.709

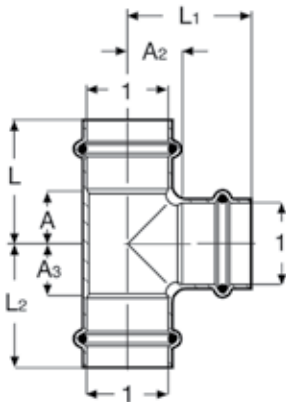

Tee P x P x P w/ EPDM Seals Model - 0118 / 4018

Catalog No.		Size	A	A2	A3	L	L1	L2
S/S 304	S/S 316	1	(in)	(in)	(in)	(in)	(in)	(in)
85580	80580	1/2"	0.748	0.748	0.748	1.496	1.496	1.496
85585	80585	3/4"	0.965	0.965	0.965	1.870	1.870	1.870
85590	80590	1"	1.122	1.122	1.122	2.028	2.028	2.028
85595	80595	1-1/4"	1.033	1.033	1.033	2.067	2.067	2.067
85600	80600	1-1/2"	1.250	1.250	1.250	2.677	2.677	2.677
85605	80605	2"	1.528	1.528	1.528	3.110	3.110	3.110

Tee P x P x P w/ FKM Seals Model - 6018

Catalog No.		Size	A	A2	A3	L	L1	L2
S/S 304	S/S 316	1	(in)	(in)	(in)	(in)	(in)	(in)
85582	80582	1/2"	0.748	0.748	0.748	1.496	1.496	1.496
85587	80587	3/4"	0.965	0.965	0.965	1.870	1.870	1.870
85592	80592	1"	1.122	1.122	1.122	2.028	2.028	2.028
85597	80597	1-1/4"	1.033	1.033	1.033	2.067	2.067	2.067
85602	80602	1-1/2"	1.250	1.250	1.250	2.677	2.677	2.677
85607	80607	2"	1.528	1.528	1.528	3.110	3.110	3.110

Dimensional Documentation

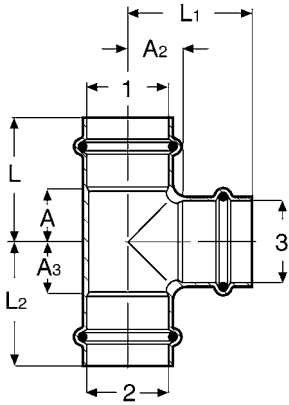

Reducing Tee P x P x P w/ EPDM Seals Model - 0118 / 4018

Catalog No.		Size			A	A2	A3	L	L1	L2
S/S 304	S/S 316	1	2	3	(in)	(in)	(in)	(in)	(in)	(in)
85630	80630	3/4" x 3/4" x 1/2"			0.965	0.925	0.965	1.870	1.673	1.870
85640	80640	1" x 1" x 1/2"			1.122	1.046	1.122	2.028	1.780	2.028
85650	80650	1" x 1" x 3/4"			1.122	1.070	1.122	2.028	1.976	2.028
85660	80660	1-1/4" x 1-1/4" x 1/2"			1.033	1.161	1.033	2.067	1.909	2.067
85670	80670	1-1/4" x 1-1/4" x 3/4"			1.033	1.220	1.033	2.067	2.126	2.067
85680	80680	1-1/4" x 1-1/4" x 1"			1.033	1.272	1.033	2.067	2.177	2.067
85690	80690	1-1/2" x 1-1/2" x 1/2"			1.250	1.315	1.250	2.677	2.063	2.677
85700	80700	1-1/2" x 1-1/2" x 3/4"			1.250	1.374	1.250	2.677	2.280	2.677
85710	80710	1-1/2" x 1-1/2" x 1"			1.250	1.425	1.250	2.677	2.330	2.677
85720	80720	2" x 2" x 1/2"			1.528	1.535	1.528	3.110	2.283	3.110
85730	80730	2" x 2" x 3/4"			1.528	1.614	1.528	3.110	2.519	3.110
85740	80740	2" x 2" x 1"			1.528	1.665	1.528	3.110	2.571	3.110
85750	80750	2" x 2" x 1-1/2"			1.528	1.488	1.528	3.110	2.913	3.110

Reducing Tee P x P x P w/ FKM Seals Model - 6018

Catalog No.		Size			A	A2	A3	L	L1	L2
S/S 304		1	2	3	(in)	(in)	(in)	(in)	(in)	(in)
85632		3/4" x 3/4" x 1/2"			0.965	0.925	0.965	1.870	1.673	1.870
85642		1" x 1" x 1/2"			1.122	1.046	1.122	2.028	1.780	2.028
85652		1" x 1" x 3/4"			1.122	1.070	1.122	2.028	1.976	2.028
85662		1-1/4" x 1-1/4" x 1/2"			1.033	1.161	1.033	2.067	1.909	2.067
85672		1-1/4" x 1-1/4" x 3/4"			1.033	1.220	1.033	2.067	2.126	2.067
85682		1-1/4" x 1-1/4" x 1"			1.033	1.272	1.033	2.067	2.177	2.067
85692		1-1/2" x 1-1/2" x 1/2"			1.250	1.315	1.250	2.677	2.063	2.677
85702		1-1/2" x 1-1/2" x 3/4"			1.250	1.374	1.250	2.677	2.280	2.677
85712		1-1/2" x 1-1/2" x 1"			1.250	1.425	1.250	2.677	2.330	2.677
85722		2" x 2" x 1/2"			1.528	1.535	1.528	3.110	2.283	3.110
85732		2" x 2" x 3/4"			1.528	1.614	1.528	3.110	2.519	3.110
85742		2" x 2" x 1"			1.528	1.665	1.528	3.110	2.571	3.110
85752		2" x 2" x 1-1/2"			1.528	1.488	1.528	3.110	2.913	3.110

Dimensional Documentation

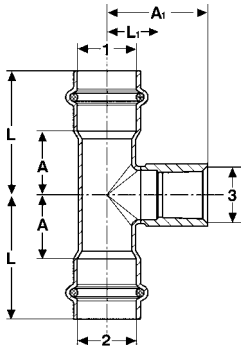

Reducing Tee P x P x F NPT w/ EPDM Seals Model - 01172 / 40172

Catalog No.		Size	A	A1	L	L1
S/S 304	S/S 316	1 2 3	(in)	(in)	(in)	(in)
85820	80820	3/4" x 3/4" x 1/2" NPT	0.963	0.980	1.868	1.546
85830	80830	3/4" x 3/4" x 3/4" NPT	0.963	0.902	1.868	1.457
85840	80840	1" x 1" x 1/2" NPT	1.122	10.870	2.028	1.622
85850	80850	1" x 1" x 3/4" NPT	1.122	1.008	2.028	1.563
85860	80860	1-1/4" x 1-1/4" x 1/2" NPT	1.033	1.236	2.067	1.772
85870	80870	1-1/4" x 1-1/4" x 3/4" NPT	1.033	1.157	2.067	1.713
85880	80880	1-1/4" x 1-1/4" x 1" NPT	1.033	1.130	2.067	1.791
85890	80890	1-1/2" x 1-1/2" x 1/2" NPT	1.250	1.388	2.677	1.924
85900	80900	1-1/2" x 1-1/2" x 3/4" NPT	1.250	1.309	2.677	1.865
85910	80910	1-1/2" x 1-1/2" x 1" NPT	1.250	1.282	2.677	1.943
85920	80920	2" x 2" x 1/2" NPT	1.528	1.610	3.110	2.146
85930	80930	2" x 2" x 3/4" NPT	1.528	1.531	3.110	2.087
85940	80940	2" x 2" x 1" NPT	1.528	1.504	3.110	2.165

Reducing Tee P x P x F NPT w/ FKM Seals Model - 6017.2

Catalog No.		Size	A	A1	L	L1
S/S 304		1 2 3	(in)	(in)	(in)	(in)
85822		3/4" x 3/4" x 1/2" NPT	0.963	0.980	1.868	1.546
85832		3/4" x 3/4" x 3/4" NPT	0.963	0.902	1.868	1.457
85842		1" x 1" x 1/2" NPT	1.122	10.870	2.028	1.622
85852		1" x 1" x 3/4" NPT	1.122	1.008	2.028	1.563
85862		1-1/4" x 1-1/4" x 1/2" NPT	1.033	1.236	2.067	1.772
85872		1-1/4" x 1-1/4" x 3/4" NPT	1.033	1.157	2.067	1.713
85882		1-1/4" x 1-1/4" x 1" NPT	1.033	1.130	2.067	1.791
85892		1-1/2" x 1-1/2" x 1/2" NPT	1.250	1.388	2.677	1.924
85902		1-1/2" x 1-1/2" x 3/4" NPT	1.250	1.309	2.677	1.865
85912		1-1/2" x 1-1/2" x 1" NPT	1.250	1.282	2.677	1.943
85922		2" x 2" x 1/2" NPT	1.528	1.610	3.110	2.146
85932		2" x 2" x 3/4" NPT	1.528	1.531	3.110	2.087
85942		2" x 2" x 1" NPT	1.528	1.504	3.110	2.165

Dimensional Documentation

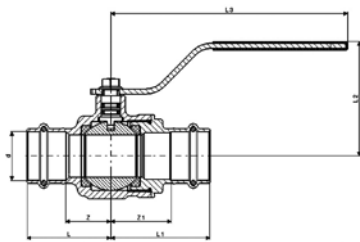

316 Stainless Steel Ball Valve P x P w/ EPDM Seals Model - 4070

Catalog No.	Size	A (in)	B (in)	C (in)	D (in)
S/S 316					
81080	1/2"	0.650	3.543	4.331	2.382
81085	3/4"	0.787	4.193	4.331	2.461
81090	1"	0.984	4.567	4.823	2.795
81095	1-1/4"	1.260	5.217	4.823	3.228
81100	1-1/2"	1.575	6.496	5.315	3.661
81105	2"	1.969	7.323	5.315	3.976

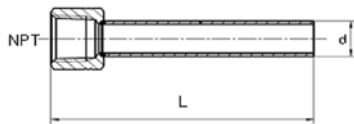

Instrument Adapter Model - 40125

Catalog No.	Size	L (in)	d (in)
S/S 316	NPT		
80126	1/2"	4.000	1.870
80127	3/4"	4.000	2.354

Dimensional Documentation

Viega ProPress for stainless XL-S 2-1/2" to 4"

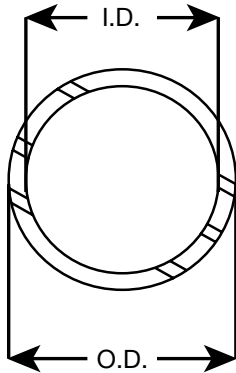

Viega ProPress for stainless steel 304 ECO-Pipe XL ASTM A554

Catalog No.	Size	O.D. (in)	I.D. (in)	Wall Thickness	Length (ft)
87080	2-1/2"	2.63	2.48	0.07	20
87085	3"	3.13	2.98	0.07	20
87090	4"	4.13	3.98	0.07	20

Viega ProPress for stainless steel 304 & 316 Pipe XL ASTM A312

Catalog No.	Size	O.D. (in)	I.D. (in)	Wall Thickness	Length (ft)	
S/S 304	S/S 316					
87095	82042	2-1/2"	2.63	2.47	0.08	20
87100	82050	3"	3.13	2.97	0.08	20
87105	82055	4"	4.13	3.97	0.08	20

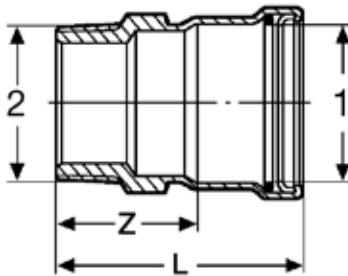

Adapter P x M NPT w/ EPDM seals Model - 0111 XL / 4011 XL

Catalog No.	Size	Z (in)	L (in)	
S/S 304	S/S 316	1 2		
85060	80060	2-1/2" x 2-1/2" NPT	2.992	4.685
85065	80065	3" x 3" NPT	3.091	5.059
85070	80070	4" x 4" NPT	3.130	5.492

Adapter P x M NPT w/ FKM seal Model - 6011 XL / 4311 XL

Catalog No.	Size	Z (in)	L (in)	
S/S 304	S/S 316	1 2		
85062	80062	2-1/2" x 2-1/2" NPT	2.992	4.685
85067	80066	3" x 3" NPT	3.091	5.059
85072	80072	4" x 4" NPT	3.130	5.492

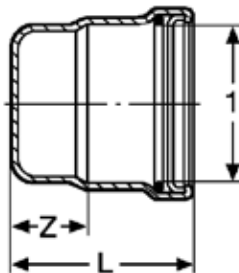

Cap x P w/ EPDM seals Model - 01561 XL / 40561 XL

Catalog No.	Size	Z (in)	L (in)	
S/S 304	S/S 316	1		
85385	80385	2-1/2"	1.319	3.012
85390	80390	3"	1.358	3.327
85395	80395	4"	1.358	3.720

Cap x P w/ FKM seal Model - 60561 XL / 43561 XL

Catalog No.	Size	Z (in)	L (in)	
S/S 304	S/S 316	1		
85387	80387	2-1/2"	1.319	3.012
85392	80392	3"	1.358	3.327
85397	80397	4"	1.358	3.720

Dimensional Documentation

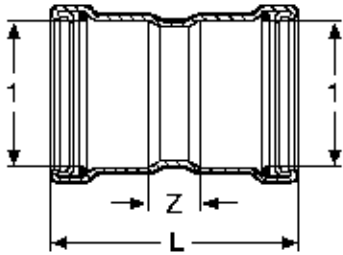

Coupling P x P w/ Stop w/ EPDM seals Model - 0115 XL / 4015 XL

Catalog No.		Size	Z	L
S/S 304	S/S 316	1	(in)	(in)
85295	80295	2-1/2"	0.945	4.331
85300	80300	3"	0.984	4.921
85305	80305	4"	1.063	5.787

Coupling P x P w/ Stop w/ FKM seals Model - 6015 XL / 4315 XL

Catalog No.		Size	Z	L
S/S 304	S/S 316	1	(in)	(in)
85297	80297	2-1/2"	0.945	4.331
85302	80302	3"	0.984	4.921
85307	80307	4"	1.063	5.787

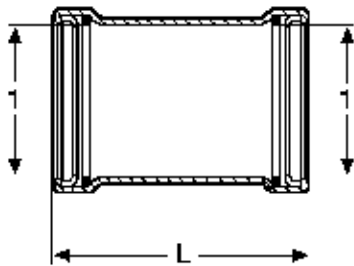

Slip Coupling P x P w/ EPDM seals Model - 01155 XL / 40155 XL

Catalog No.		Size	L
S/S 304	S/S 316	1	(in)
85340	80340	2-1/2"	4.331
85345	80345	3"	4.921
85350	80350	4"	5.787

Slip Coupling P x P w/ FKM seals Model - 60155 XL / 43155 XL

Catalog No.		Size	L
S/S 304	S/S 316	1	(in)
85342	80342	2-1/2"	4.331
85347	80347	3"	4.921
85352	80352	4"	5.787

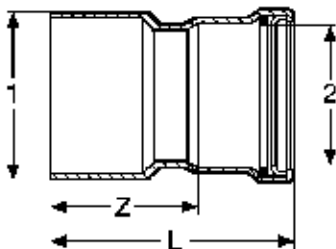

Reducer FTG x P w/ EPDM seals Model - 01151 XL / 40151 XL

Catalog No.		Size	Z	L
S/S 304	S/S 316	1 2	(in)	(in)
85235	80235	2-1/2" x 2"	2.835	4.409
85240	80240	3" x 2"	3.386	4.961
85245	80245	3" x 2-1/2"	3.209	4.902
85250	80250	4" x 2"	4.272	5.846
85255	80255	4" x 2-1/2"	4.094	5.787
85260	80260	4" x 3"	3.878	5.846

Reducer FTG x P w/ FKM seals Model - 60151 XL / 43151 XL

Catalog No.		Size	Z	L
S/S 304	S/S 316	1 2	(in)	(in)
85237	80237	2-1/2" x 2"	2.835	4.409
85242	80242	3" x 2"	3.386	4.961
85247	80247	3" x 2-1/2"	3.209	4.902
85252	80252	4" x 2"	4.272	5.846
85257	80257	4" x 2-1/2"	4.094	5.787
85262	80262	4" x 3"	3.878	5.846

Dimensional Documentation

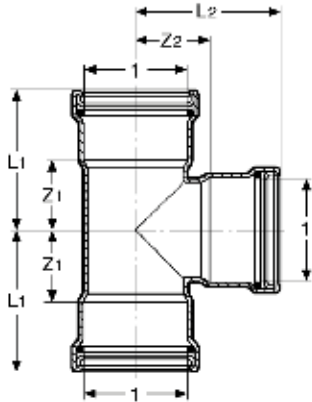

Tee P x P x P w/ EPDM seals Model - 0118 XL / 4018 XL

Catalog No.		Size	Z 1	Z2	L1	L2
S/S 304	S/S 316	1	(in)	(in)	(in)	(in)
85610	80610	2-1/2"	1.831	1.870	3.524	3.563
85615	80615	3"	2.067	2.146	4.035	4.114
85620	80620	4"	2.598	2.657	4.961	5.020

Tee P x P x P w/ FKM seals Model - 6018 XL / 4318 XL

Catalog No.		Size	Z 1	Z2	L1	L2
S/S 304	S/S 316	1	(in)	(in)	(in)	(in)
85612	80612	2-1/2"	1.831	1.870	3.524	3.563
85617	80617	3"	2.067	2.146	4.035	4.114
85622	80622	4"	2.598	2.657	4.961	5.020

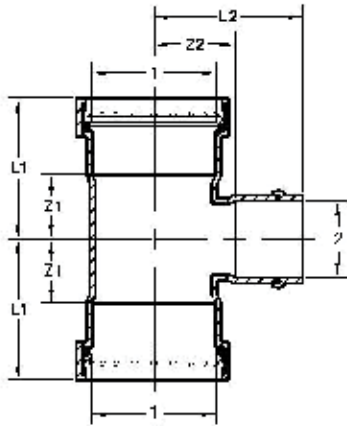

Reducing Tee P x P x P w/ EPDM seals Model - 0118 XL / 4018 XL

Catalog No.		Size	Z 1	Z2	L1	L2
S/S 304	S/S 316	1 2	(in)	(in)	(in)	(in)
85761	80761	2-1/2" x 1-1/2"	1.299	1.744	2.992	3.169
85760	80760	2-1/2" x 2"	1.535	1.772	3.228	3.346
85772	80772	3" x 1-1/4"	1.240	1.929	3.209	2.953
85771	80771	3" x 1-1/2"	1.319	2.008	3.287	3.425
85770	80770	3" x 2"	1.555	2.008	3.524	3.583
85780	80780	3" x 2-1/2"	1.850	2.126	3.819	3.819
85791	80791	4" x 1-1/2"	1.358	2.520	3.720	3.937
85790	80790	4" x 2"	1.594	2.520	3.957	4.094
85800	80800	4" x 2-1/2"	1.890	2.638	4.252	4.331
85810	80810	4" x 3"	2.067	2.657	4.469	4.626

Reducing Tee P x P x P w/ FKM seals Model - 6018 XL / 4318 XL

Catalog No.		Size	Z 1	Z2	L1	L2
S/S 304	S/S 316	1 2	(in)	(in)	(in)	(in)
85934	80934	2-1/2" x 1-1/2"	1.299	1.744	2.992	3.169
85904	80904	2-1/2" x 2"	1.535	1.772	3.228	3.346
85944	80944	3" x 1-1/4"	1.240	1.929	3.209	2.953
85935	80955	3" x 1-1/2"	1.319	2.008	3.287	3.425
85905	80905	3" x 2"	1.555	2.008	3.524	3.583
85914	80914	3" x 2-1/2"	1.850	2.126	3.819	3.819
85945	80945	4" x 1-1/2"	1.358	2.520	3.720	3.937
85915	80915	4" x 2"	1.594	2.520	3.957	4.094
85924	80924	4" x 2-1/2"	1.890	2.638	4.252	4.331
85925	80925	4" x 3"	2.067	2.657	4.469	4.626

Dimensional Documentation

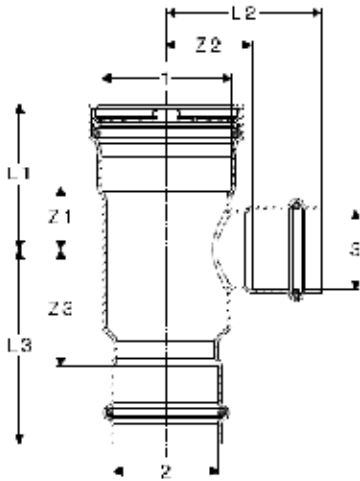

Reducing Tee P x P x P w/ EPDM seals Model - 0118 XL / 4018 XL

Catalog No.		Size			Z 1	Z 2	Z 3	L 1	L 2	L 3
S/S 304	S/S 316	1	2	3	(in)	(in)	(in)	(in)	(in)	(in)
85763	80763	2-1/2" x 2" x 1-1/2"			1.299	1.744	2.386	2.992	3.169	3.961
85762	80762	2-1/2" x 2" x 2"			1.535	1.791	2.697	3.228	3.366	4.272

Reducing Tee P x P x P w/ FKM seals Model - 6018 XL / 4318 XL

Catalog No.		Size			Z 1	Z 2	Z 3	L 1	L 2	L 3
S/S 304	S/S 316	1	2	3	(in)	(in)	(in)	(in)	(in)	(in)
85955	80594	2-1/2" x 2" x 1-1/2"			1.299	1.744	2.386	2.992	3.169	3.961
85954	80935	2-1/2" x 2" x 2"			1.535	1.791	2.697	3.228	3.366	4.272

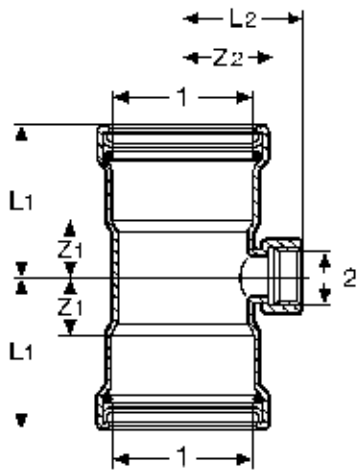

Reducing Tee P x P x F NPT w/ EPDM Seals Model - 01172 XL / 40172 XL

Catalog No.		Size		Z 1	Z 2	L 1	L 2
S/S 304	S/S 316	1	2	(in)	(in)	(in)	(in)
85950	80950	2-1/2" x 3/4"		1.024	1.807	2.717	2.362
85960	80960	2-1/2" x 1"		1.024	1.740	2.717	2.402
85970	80970	3" x 3/4"		1.043	2.004	3.012	2.559
85980	80980	3" x 1"		1.043	1.976	3.012	2.638
85990	80990	4" x 3/4"		1.083	2.516	3.445	3.071
86000	81000	4" x 1"		1.083	2.488	3.445	3.150

Reducing Tee P x P x F NPT w/ FKM Seals Model - 01172 XL / 40172 XL

Catalog No.		Size		Z 1	Z 2	L 1	L 2
S/S 304	S/S 316	1	2	(in)	(in)	(in)	(in)
85950	80950	2-1/2" x 3/4"		1.024	1.807	2.717	2.362
85960	80960	2-1/2" x 1"		1.024	1.740	2.717	2.402
85970	80970	3" x 3/4"		1.043	2.004	3.012	2.559
85980	80980	3" x 1"		1.043	1.976	3.012	2.638
85990	80990	4" x 3/4"		1.083	2.516	3.445	3.071
86000	81000	4" x 1"		1.083	2.488	3.445	3.150

Dimensional Documentation

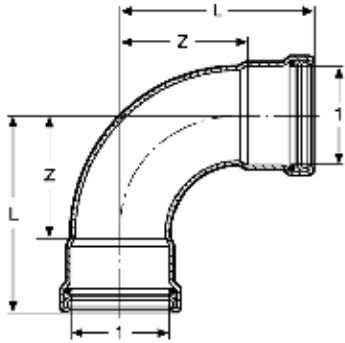

EII 90° P x P w/ EPDM seals Model - 0116 XL / 4016 XL

Catalog No.		Size	Z	L
S/S 304	S/S 316	1	(in)	(in)
85430	80430	2-1/2"	3.189	4.882
85435	80435	3"	3.760	5.728
85440	80440	4"	4.862	7.224

EII 90° P x P w/ FKM seals Model - 6016 XL / 4316 XL

Catalog No.		Size	Z	L
S/S 304	S/S 316	1	(in)	(in)
85432	80432	2-1/2"	3.189	4.882
85437	80437	3"	3.760	5.728
85442	80442	4"	4.862	7.224

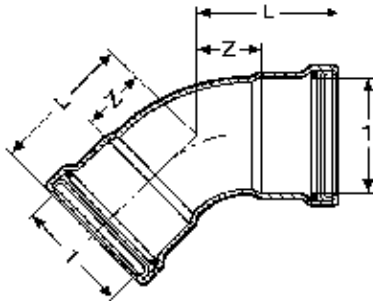

EII 45° P x P w/ EPDM seals Model - 0126 XL / 4026 XL

Catalog No.		Size	Z	L
S/S 304	S/S 316	1	(in)	(in)
85475	80475	2-1/2"	1.484	3.177
85480	80480	3"	1.732	3.701
85485	80485	4"	2.189	4.551

EII 45° P x P w/ FKM seals Model - 6026 XL / 4326 XL

Catalog No.		Size	Z	L
S/S 304	S/S 316	1	(in)	(in)
85477	80477	2-1/2"	1.484	3.177
85482	80482	3"	1.732	3.701
85487	80487	4"	2.189	4.551

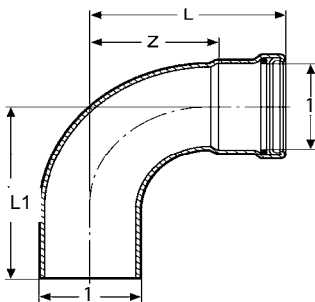

EII 90° FTG x P w/ EPDM seals Model - 01161 XL / 40161 XL

Catalog No.		Size	Z	L	L1
S/S 304	S/S 316	1	(in)	(in)	(in)
85520	80520	2-1/2"	3.189	4.882	4.803
85525	80525	3"	3.760	5.728	5.630
85530	80530	4"	4.862	7.224	7.126

EII 90° FTG x P w/ FKM seals Model - 60161 XL / 43161 XL

Catalog No.		Size	Z	L	L1
S/S 304	S/S 316	1	(in)	(in)	(in)
85522	80522	2-1/2"	3.189	4.882	4.803
85527	80532	3"	3.760	5.728	5.630
85532	80433	4"	4.862	7.224	7.126

Dimensional Documentation

EII 45° FTG x P w/ EPDM seals Model - 01261 XL / 40261 XL

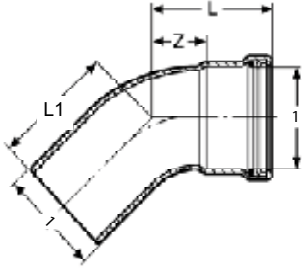

Catalog No.		Size	Z	L	L1
S/S 304	S/S 316	1	(in)	(in)	(in)
85565	80565	2-1/2"	1.484	3.177	3.098
85570	80570	3"	1.732	3.701	3.602
85575	80575	4"	2.189	4.551	4.453

EII 45° FTG x P w/ FKM seals Model - 60261 XL / 43261 XL

Catalog No.		Size	Z	L	L1
S/S 304	S/S 316	1	(in)	(in)	(in)
85567	80567	2-1/2"	1.484	3.177	3.098
85572	80572	3"	1.732	3.701	3.602
85577	80577	4"	2.189	4.551	4.453

Flange P x Flange w/ EPDM seals Model - 0159 XL / 4059 XL

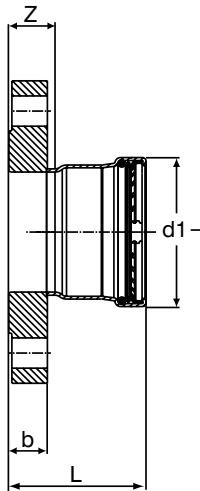

Catalog No.		Size	Z	L	b	D	k	d2
S/S 304	S/S 316	1	(in)	(in)	(in)	(in)	(in)	(in)
86065	81065	2-1/2"	1.346	3.039	0.894	7.087	5.512	0.748
86070	81070	3"	1.429	3.398	0.957	7.480	5.984	0.748
86075	81075	4"	1.429	3.791	0.957	9.055	7.520	0.748

Flange P x Flange w/ FKM seals Model - 6059 XL / 4359 XL

Catalog No.		Size	Z	L	b	D	k	d2
S/S 304	S/S 316	1	(in)	(in)	(in)	(in)	(in)	(in)
86067	81067	2-1/2"	1.346	3.039	0.894	7.087	5.512	0.748
86072	81072	3"	1.429	3.398	0.957	7.480	5.984	0.748
86077	81077	4"	1.429	3.791	0.957	9.055	7.520	0.748

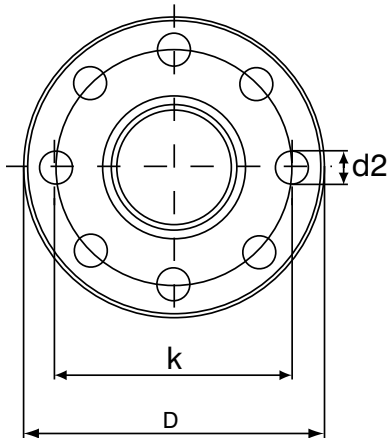

Dimensional Documentation

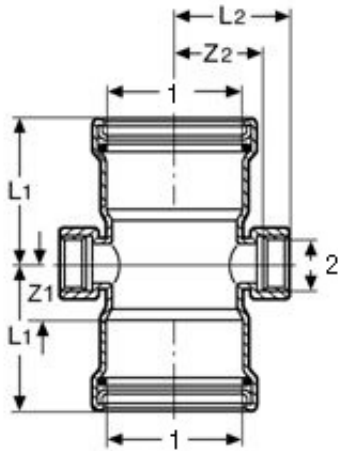

Cross P x P x F NPT x F NPT w/ EPDM seals Model - 40441 XL

S/S 316	Size		Z 1	Z 2	L 1	L 2
	1	2	(in)	(in)	(in)	(in)
80067	2-1/2" x 3/4"		1.024	1.087	2.717	2.362
80069	3" x 3/4"		1.043	2.004	3.012	2.559
80068	4" x 3/4"		1.083	2.516	3.445	3.071

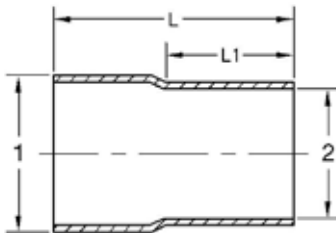

Transition P x Weld - w/out Seal Model - 0113.1XL & 4013.1XL

Catalog No.		Size		L	L 1
S/S 304	S/S 316	1	2	(in)	(in)
85135	80081	2-1/2" ID	2-1/2" OD	4.370	2.323
85145	80082	3" ID	3" OD	4.567	2.598
85155	80083	4" ID	4" OD	5.157	2.992

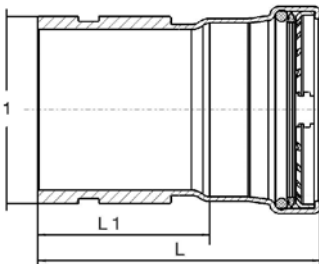

Transition P x Groove - EPDM Seals Model - 0113.2XL & 4013.2XL

Catalog No.		Size	L	L 1
S/S 304	S/S 316	1	(in)	(in)
85166	80064	2-1/2"	4.331	2.638
85177	80061	3"	4.626	4.528
85188	80063	4"	5.020	5.315

Engineering Data

Viega ProPress for stainless 304/316 Pipe – Schedule 5

Pipe Dimensional Data

Nominal Pipe Size	Nominal Dimensions							
	Outside Diameter (OD)		Inside Diameter (ID)		Wall Thickness		Weight	
	inches	mm	inches	mm	inches	mm	lb./ft.	lb./stick
1/2"	0.63	16.00	0.49	12.45	0.07	1.78	0.41	8.20
3/4"	0.88	22.35	0.74	18.80	0.07	1.78	0.59	11.80
1"	1.13	28.70	0.99	25.15	0.07	1.78	0.77	15.40
1-1/4"	1.38	35.05	1.24	31.50	0.07	1.78	0.95	19.00
1-1/2"	1.63	41.40	1.49	37.85	0.07	1.78	1.13	22.60
2"	2.13	54.10	1.99	50.55	0.07	1.78	1.50	30.00
2-1/2"	2.63	66.68	2.47	62.74	0.08	2.03	2.18	43.60
3"	3.13	79.50	2.97	75.44	0.08	2.03	2.60	52.00
4"	4.13	104.90	3.97	100.84	0.08	2.03	3.46	69.20

Weight Data

Nominal Pipe Size	Weight		
	Pipe (lb./ft.)	Water (lb./ft.)	Total (lb./ft.)
1/2"	0.41	0.06	0.47
3/4"	0.59	0.12	0.71
1"	0.77	0.20	0.97
1-1/4"	0.95	0.31	1.26
1-1/2"	1.13	0.43	1.56
2"	1.50	0.76	2.26
2-1/2"	2.18	1.61	3.79
3"	2.60	2.29	4.89
4"	3.46	4.06	7.52

Engineering Data

Viega ProPress for stainless Flow Data

1/2" Stainless Steel, ASTM A312

Flow Rate (gpm)	Schedule 5	
	Wall Thickness = 0.07 ID = 0.490	
	Velocity (ft/sec)	Press Loss (psi/100')
1.00	1.70	1.05
2.00	3.40	4.20
3.00	5.10	9.44
4.00	6.81	16.79
5.00	8.51	26.23
6.00	10.21	37.78
7.00	11.91	51.42
8.00	13.61	67.16
9.00	15.31	85.00
10.00	17.01	104.94
11.00	18.71	126.98
12.00	20.42	151.11
13.00	22.12	177.35
14.00	23.82	205.68
15.00	25.52	236.11
16.00	27.22	268.64
17.00	28.92	303.27
18.00	30.62	340.00

3/4" Stainless Steel, ASTM A312

Flow Rate (gpm)	Schedule 5	
	Wall Thickness = 0.07 ID = 0.740	
	Velocity (ft./sec.)	Press Loss (psi/100')
1.00	0.75	0.13
2.00	1.49	0.51
3.00	2.24	1.15
4.00	2.98	2.04
5.00	3.73	3.19
6.00	4.48	4.59
7.00	5.22	6.25
8.00	5.97	8.16
9.00	6.71	10.33
10.00	7.46	12.75
11.00	8.21	15.43
12.00	8.95	18.36
13.00	9.70	21.55
14.00	10.44	24.99
15.00	11.19	28.69
16.00	11.94	32.64
17.00	12.68	36.85
18.00	13.43	41.32
19.00	14.17	46.03
20.00	14.92	51.01
21.00	15.67	56.23
22.00	16.41	61.72
23.00	17.16	67.46
24.00	17.90	73.45
25.00	18.65	79.70
26.00	19.40	86.20
27.00	20.14	92.96
28.00	20.89	99.97
29.00	21.63	107.24
30.00	22.38	114.77

Engineering Data

1" Stainless Steel, ASTM A312

Flow Rate (gpm)	Schedule 5	
	Wall Thickness = 0.07 ID = 0.990	
	Velocity (ft./sec.)	Press Loss (psi/100')
2.00	0.83	0.11
4.00	1.67	0.45
6.00	2.50	1.02
8.00	3.33	1.81
10.00	4.17	2.83
12.00	5.00	4.08
14.00	5.84	5.55
16.00	6.67	7.25
18.00	7.50	9.18
20.00	8.34	11.33
22.00	9.17	13.72
24.00	10.00	16.32
26.00	10.84	19.16
28.00	11.67	22.22
30.00	12.50	25.50
32.00	13.34	29.02
34.00	14.17	32.76
36.00	15.00	36.73
38.00	15.84	40.92
40.00	16.67	45.34
42.00	17.51	49.99
44.00	18.34	54.86
46.00	19.17	59.96

1-1/4" Stainless Steel, ASTM A312

Flow Rate (gpm)	Schedule 5	
	Wall Thickness = 0.07 ID = 1.24	
	Velocity (ft./sec.)	Press Loss (psi/100')
5.00	1.33	0.23
8.00	2.13	0.59
11.00	2.92	1.11
14.00	3.72	1.80
17.00	4.52	2.66
20.00	5.31	3.68
23.00	6.11	4.86
26.00	6.91	6.21
29.00	7.70	7.73
32.00	8.50	9.41
35.00	9.30	11.26
38.00	10.10	13.27
41.00	10.89	15.45
44.00	11.69	17.80
47.00	12.49	20.31
50.00	13.28	22.98
53.00	14.08	25.82
56.00	14.88	28.83
59.00	15.67	32.00
62.00	16.47	35.33
65.00	17.27	38.84
68.00	18.07	42.50
71.00	18.86	46.34
74.00	19.66	50.34
77.00	20.46	54.50

Engineering Data

1-1/2" Stainless Steel, ASTM A312

Flow Rate (gpm)	Schedule 5	
	Wall Thickness = 0.07 ID = 1.49	
	Velocity (ft./sec.)	Press Loss (psi/100')
10.00	1.84	0.35
13.00	2.39	0.59
16.00	2.94	0.89
19.00	3.50	1.26
22.00	4.05	1.69
25.00	4.60	2.18
28.00	5.15	2.73
31.00	5.70	3.35
34.00	6.26	4.03
37.00	6.81	4.77
40.00	7.36	5.58
43.00	7.91	6.45
46.00	8.46	7.38
49.00	9.02	8.37
52.00	9.57	9.43
55.00	10.12	10.55
58.00	10.67	11.73
61.00	11.22	12.97
64.00	11.78	14.28
67.00	12.33	15.65
70.00	12.88	17.08
73.00	13.43	18.58
76.00	13.98	20.14
79.00	14.54	21.76
82.00	15.09	23.44
85.00	15.64	25.19
88.00	16.19	27.00
91.00	16.74	28.87

2" Stainless Steel, ASTM A312

Flow Rate (gpm)	Schedule 5	
	Wall Thickness = 0.07 ID = 1.990	
	Velocity (ft./sec.)	Press Loss (psi/100')
20.00	2.06	0.31
25.00	2.58	0.49
30.00	3.09	0.70
35.00	3.61	0.95
40.00	4.13	1.24
45.00	4.64	1.57
50.00	5.16	1.94
55.00	5.67	2.35
60.00	6.19	2.80
65.00	6.70	3.28
70.00	7.22	3.81
75.00	7.74	4.37
80.00	8.25	4.97
85.00	8.77	5.61
90.00	9.28	6.29
95.00	9.80	7.01
100.00	10.32	7.77
105.00	10.83	8.57
110.00	11.35	9.40
115.00	11.86	10.28
120.00	12.38	11.19
125.00	12.89	12.14
130.00	13.41	13.13
135.00	13.93	14.16
140.00	14.44	15.23
145.00	14.96	16.34
150.00	15.47	17.49
155.00	15.99	18.67
160.00	16.50	19.89
165.00	17.02	21.16

Engineering Data

2-1/2" Stainless Steel, ASTM A312

Flow Rate (gpm)	Schedule 5	
	Wall Thickness = 0.08 ID = 2.470	
	Velocity (ft./sec.)	Press Loss (psi/100')
50.00	3.35	0.62
55.00	3.68	0.75
60.00	4.02	0.90
65.00	4.35	1.05
70.00	4.69	1.22
75.00	5.02	1.40
80.00	5.36	1.59
85.00	5.69	1.80
90.00	6.03	2.02
95.00	6.36	2.25
100.00	6.70	2.49
105.00	7.03	2.75
110.00	7.37	3.01
115.00	7.70	3.30
120.00	8.03	3.59
125.00	8.37	3.89
130.00	8.70	4.21
135.00	9.04	4.54
140.00	9.37	4.88
145.00	9.71	5.24
150.00	10.04	5.61
155.00	10.38	5.99
160.00	10.71	6.38
165.00	11.05	6.78
170.00	11.38	7.20
175.00	11.72	7.63
180.00	12.05	8.07
185.00	12.39	8.53
190.00	12.72	8.99
195.00	13.06	9.47
200.00	13.39	9.97

3" Stainless Steel, ASTM A312

Flow Rate (gpm)	Schedule 5	
	Wall Thickness = 0.08 ID = 2.970	
	Velocity (ft./sec.)	Press Loss (psi/100')
50.00	2.32	0.25
60.00	2.78	0.36
70.00	3.24	0.49
80.00	3.70	0.63
90.00	4.17	0.80
100.00	4.63	0.99
110.00	5.09	1.20
120.00	5.56	1.43
130.00	6.02	1.68
140.00	6.48	1.94
150.00	6.95	2.23
160.00	7.41	2.54
170.00	7.87	2.86
180.00	8.34	3.21
190.00	8.80	3.58
200.00	9.26	3.96
210.00	9.73	4.37
220.00	10.19	4.80
230.00	10.65	5.24
240.00	11.11	5.71
250.00	11.58	6.20
260.00	12.04	6.70
270.00	12.50	7.23
280.00	12.97	7.77
290.00	13.43	8.34
300.00	13.89	8.92
310.00	14.36	9.53
320.00	14.82	10.15
330.00	15.28	10.79
340.00	15.75	11.46
350.00	16.21	12.14
360.00	16.67	12.85
370.00	17.13	13.57
380.00	17.60	14.31
390.00	18.06	15.08

Engineering Data

4" Stainless Steel, ASTM A312

Flow Rate (gpm)	Schedule 5	
	Wall Thickness = 0.08 ID = 3.970	
	Velocity (ft./sec.)	Press Loss (psi/100')
200.00	5.18	0.93
220.00	5.70	1.12
240.00	6.22	1.34
260.00	6.74	1.57
280.00	7.26	1.82
300.00	7.78	2.09
320.00	8.29	2.38
340.00	8.81	2.69
360.00	9.33	3.01
380.00	9.85	3.35
400.00	10.37	3.72
420.00	10.89	4.10
440.00	11.40	4.50
460.00	11.92	4.91
480.00	12.44	5.35
500.00	12.96	5.81
520.00	13.48	6.28
540.00	14.00	6.77
560.00	14.51	7.28
580.00	15.03	7.81
600.00	15.55	8.36
620.00	16.07	8.93
640.00	16.59	9.51
660.00	17.11	10.12
680.00	17.62	10.74
700.00	18.14	11.38
720.00	18.66	12.04
740.00	19.18	12.72
760.00	19.70	13.42
780.00	20.22	14.13
800.00	20.73	14.87
820.00	21.25	15.62
840.00	21.77	16.39
860.00	22.29	17.18
880.00	22.81	17.99

Engineering Data

Fitting Friction Loss Equivalent Length of Pipe (ft)

Fitting Type	1/2"	3/4"	1"	1-1/4"	1-1/2"	2"	2-1/2"	3"	4"
90° elbow	0.66	0.99	1.33	1.65	1.98	2.66	3.30	3.97	5.30
45° elbow	0.66	0.99	1.33	1.65	1.98	2.66	3.30	3.97	5.30
tee (straight flow)	0.82	1.24	1.66	2.06	2.48	3.32	4.12	4.96	6.62
tee (branch outlet)	2.46	3.72	4.98	6.18	7.44	9.96	12.36	14.88	19.86
ball valve (full port)	6.15	9.30	12.45	15.45	18.60	24.90	n/a	n/a	n/a

MSS SP-69 or the following maximum spacing and minimum rod sizes

Nominal Pipe Size (in.)	Stainless Steel Pipe Max. Span (ft.)	Min. Rod Diameter (in.)
Up to 3/4	10	3/8
1	10	3/8
1-1/4	10	3/8
1-1/2	10	3/8
2	10	3/8
2-1/2	11	1/2
3	12	1/2
4	14	5/8

Protection of Viega ProPress for stainless steel fittings and pipe

Viega ProPress for stainless Steel pipe and fittings exposed to corrosive action, such as soil conditions or moisture, must be protected in an approved manner in accordance with IFGC section 404.8, NACE Standard RP0169-2002 section 5, 2009 UPC Chapter 6 section 609.3.1, 2009 UMC Chapter 13 section 1312.1.3 and in a manner satisfactory to the local code official.

Engineering Specifications

1 – Product Definition

	Viega ProPress for stainless is a complete Cold Press Mechanical Joint Piping system. The Viega ProPress for stainless system shall include pipe, valves and fittings from 1/2" to 4" in both 304 and 316 grades of stainless steel.
--	--

2 – Manufacturer

	Viega LLC. 301 N. Main 9 th FLR Wichita, KS 67202 Tel: 1-800-976-9819 www.viega.net
--	---

3 – Material

3.1	Viega ProPress for stainless steel fittings shall conform to dimensional tolerances of ASTM B88 and ANSI B16.22.
3.2	Sealing elements for Viega ProPress for stainless Steel fittings shall be EPDM or FKM. Determination shall be based on the evaluation of the system operating parameters.
3.2.1	Alternative sealing elements shall be supplied by Viega.
3.3	Press ends shall include the Smart Connect (SC) feature. Smart Connect feature assures leakage of liquid and/or gases past the fitting sealing element of an unpressed connection thus providing the installer identification of unpressed connections prior to the systems operation; and shall appear in all fittings.

3 – Material cont.

3.4	Fitting markings:
3.4.1	Fittings shall be marked with manufacturers name "Viega," size of the fitting, alloy composition (304 or 316) and appropriate production code.
3.4.2	304 stainless steel fittings with EPDM sealing elements shall be marked with orange dots indicating the 'SC' feature.
3.4.3	316 stainless steel fittings with EPDM sealing elements shall be marked with green dots indicating the 'SC' feature.
3.4.4	304 stainless steel fitting & 316 stainless steel fittings with FKM sealing elements shall be marked with white dots indicating the 'SC' feature.
3.5	Stainless steel pipe for the Viega ProPress for stainless system shall only be manufactured by "Viega". Stainless steel pipe shall conform with ASTM A312 and A554 in copper tube size conforming to ASTM B88 (CTS). Identifying pipe markings for the Viega ProPress for stainless system shall conform to ASTM A999 material variations will be Orange stripe on the pipe for 304 stainless steel; 316 stainless steel pipe will be identified by the print line along its entire length.

Engineering Specifications

4 – Installation

4.1	Fittings joints shall be made in accordance with the manufacturer's installation instructions. The pipe shall be fully inserted into the fitting and the pipe marked at the shoulder of the fitting. The fitting alignment shall be checked against the mark on the pipe to ensure the pipe is fully engaged (inserted) into the fitting.
4.2	The joints shall be pressed using a press tool recommended by Viega.

5 – Codes and Standards

5.1	Viega ProPress for stainless conforms to the following: <ul style="list-style-type: none">• ASTM A240 Specification for Chromium and ChromiumNickel Stainless Steel Plate, Sheet, and Strip for Pressure Vessels and for General Applications• ASTM A312 Specification for Seamless, Welded, and Heavily Cold Worked Austenitic Stainless Steel Pipes• ASTM A403 Specification for Wrought Austenitic Stainless Steel Piping Fittings• ASTM A554 Specification for Welded Stainless Steel Mechanical Tubing• ASTM A999 Specification for General Requirements for Alloy and Stainless Steel Pipe• ASTM B88 Specification for Seamless Copper Water Tube (dimensionally)• ASME B1.20.1 Pipe Threads, General Purpose, Inch• ASME B31.1 Power Piping• ASME B31.3 Process Piping• ASME B31.9 Building Services Piping• ASME B36.10M Welded and Seamless Wrought Steel Pipe (dimensionally for 5S pipe wall)
-----	--

Product Instruction

1/2" to 2"

⚠ WARNING

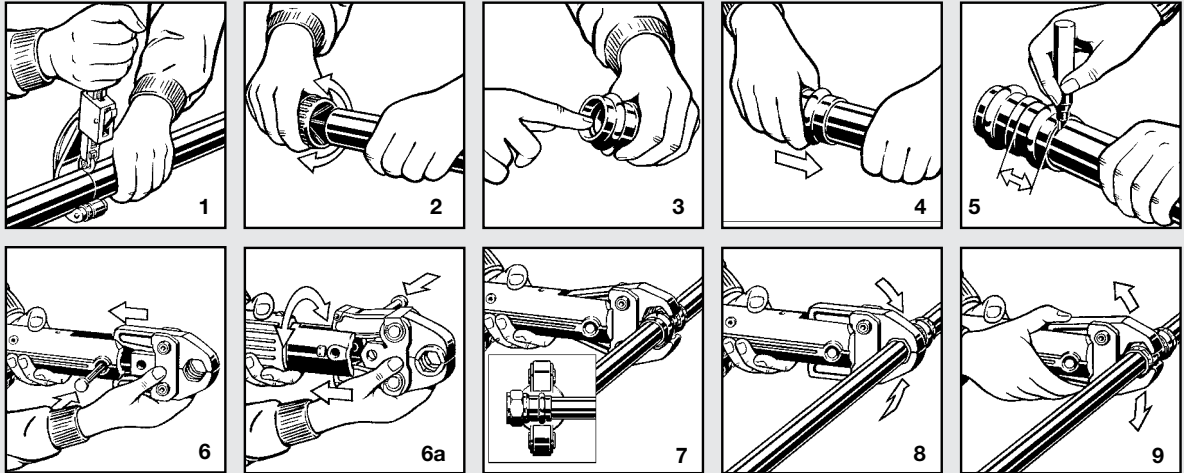

Viega ProPress Insertion Depth Chart						
Pipe Size	1/2"	3/4"	1"	1-1/4"	1-1/2"	2"
Insertion Depth	3/4"	7/8"	7/8"	1"	1-7/16"	1-9/16"

1. Cut stainless steel pipe only with an approved stainless steel pipe cutting tool. Cut pipe to permit proper joining with the fitting.
2. Remove burrs, scale, slag, dirt and debris from inside and outside of the pipe and fittings before assembly. Wipe pipe ends clean and dry.
3. Check fitting to ensure sealing element is properly seated.
4. Fitting insertion: insert pipe in fitting until stop is encountered.
5. Mark pipe to verify insertion depth.
6. Insert the appropriate fitting jaw into the press tool, lock into place.
- 6a. Tool head rotates, allowing jaws to be placed in desired position.
7. Open press jaws and place at right angles on the fitting. Visually check insertion depth using mark on pipe.
8. Start pressing procedure by holding the press tool trigger until jaws have engaged.
Note: Once press tool is operating, jaws will not open.
9. Once press process is complete, jaws can be released.



Smart Connect Feature

For Viega ProPress 1/2" to 2" dimension, the Smart Connect feature is a special indentation in the inside surface of the fitting near the sealing element. This Indentation is removed during the pressing process, creating a leak-free permanent connection. The function of the feature is to provide identification of connections which have not been pressed prior to putting the system in to operation. The function of the Smart Connect feature is carried out by pressurizing the piping system.

The Smart Connect feature may be pressure tested with air or water. When testing with air, the pressure range is 0.5 PSI to 85 PSI Maximum. When testing with water, the pressure range is 15 PSI to 85 PSI Maximum. The Smart Connect feature test is not a substitute for local code required pressure testing of the piping system. Carry out the final piping system pressure test in accordance with local codes.

Product Instruction

2-1/2" to 4"

⚠ WARNING Read, understand, and follow all instructions for installing Viega ProPress XL-S fittings. Failure to follow all instructions may result in extensive property damage, serious injury or death.

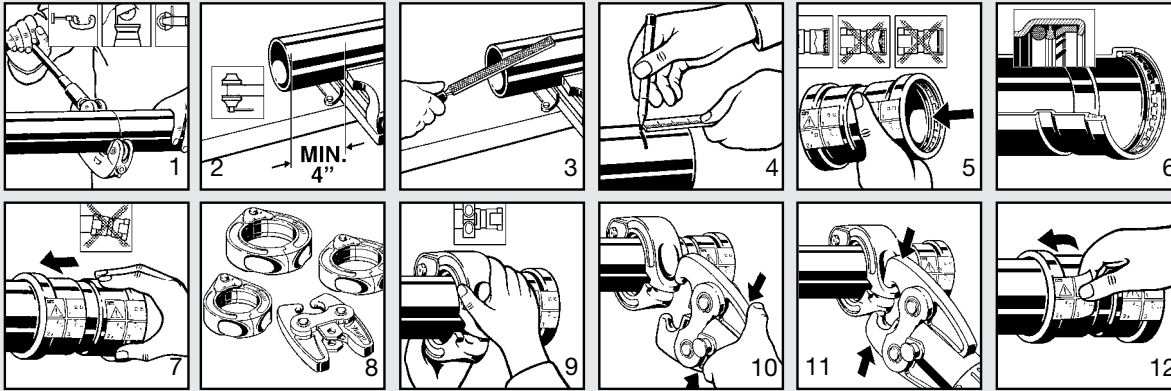

Viega ProPress for stainless XL-S Insertion Depth Chart

Pipe Size	2-1/2"	3"	4"
Insertion Depth	1-5/8"	1-7/8"	2-3/8"

- Cut stainless steel pipe at right angles using displacement type cutter or fine-toothed steel saw.
- Keep end of piping a minimum of 4" away from the contact area of the vise to prevent possible damage to the piping in the press area.
- Remove burrs from inside and outside of tubing to prevent cutting sealing element.
- Check seal and grip ring for correct fit. Do not use oils or lubricants. Use only Viega ProPress for stainless Shiny Black EPDM sealing elements.
- Mark proper insertion depth as indicated by the Viega ProPress for stainless XL Insertion Depth Chart. Improper insertion depth may result in an improper seal.
- Illustration demonstrates proper fit of grip ring, separator ring and sealing element.
- While turning slightly, slide press fitting onto tubing to the marked depth. **End of tubing must contact stop.**
- Viega ProPress for stainless XL fitting connections must be performed with Viega ProPress XL-C Rings and V2 ACTUATOR. **Use of Viega ProPress XL Rings and/or Actuator (for Bronze fittings) will result in an improper connection.** See Ridgid Operator's Manual for proper tool instructions.
- Open XL-C Ring and place at right angles on the fitting. XL-C Ring must be engaged on the fitting bead. Check insertion depth.
- With V2 ACTUATOR inserted into the tool, open the V2 ACTUATOR as shown and connect V2 ACTUATOR to the XL-C Ring.
- Place V2 ACTUATOR onto XL-C Ring and start pressing process. Hold the trigger until the Actuator has engaged the XL-C Ring. Keep extremities and foreign objects away from XL-C Ring and V2 ACTUATOR during pressing operation to prevent injury or incomplete press.
- Release V2 ACTUATOR from XL-C Ring and then remove the XL-C Ring from the fitting on completion of press. Remove tag from fitting indicating press has been performed.



Smart Connect Feature

Pressure Testing: Pressure testing is to be carried out in accordance with local codes. Viega ProPress for stainless XL also includes the Smart Connect feature, providing quick and easy identification of unpressed connections during the pressure testing process. **Unpressed connections are located by pressurizing the system with air or water. When testing with air the pressure range is 1/2 PSI to 85 PSI Maximum.** When testing with water the pressure range is 15 PSI to 85 PSI Maximum. The Smart Connect feature is an integral part of the design of the fitting assuring leakage of liquids and/or gases from inside the system past the sealing element of an unpressed connection. The Smart Connect feature is removed during the pressing process creating a leak-proof, permanent connection.

Viega ProPress for stainless Galvanic Corrosion Prevention

Galvanic corrosion (or dissimilar metal corrosion) is the process where metals in direct contact with each other corrode or oxidize. The metals corrode by creating an electrochemical path which allows metal ions to move from one metal to the other metal. Metals joined together should have an 'Anodic Index' difference of 0.25V or less to prevent galvanic corrosion under normal conditions.

Copper and stainless steel (either 304 or 316) have an 'Anodic Index' difference greater than 0.25V. Connecting copper to stainless steel requires a transition fitting between the metals to stop the galvanic corrosion.

Viega recommends the following types of fittings to stop the galvanic corrosion process between copper and stainless steel.

1. Any Viega ProPress di-electric union / Viega ProPress for stainless di-electric union
2. Any Viega ProPress flange / Viega ProPress for stainless flange



Flange

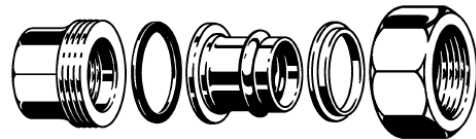

Di-electric Union

Special Products

Viega ProPress for stainless XL-S Cross

Application:

The Viega ProPress for 316 stainless steel cross can be used when making back-to-back threaded connections in General Utility, Chilled Water, Hydronic Heating, Vacuum, and Compressed Air Systems. The Viega ProPress for 316 stainless steel cross is equipped with the Smart Connect feature for easy identification of unpressed connections during pressure testing.

Viega ProPress for 316 stainless steel crosses are available in the following sizes:

2-1/2" x 2-1/2" x 3/4" F NPT x 3/4" F NPT

3" x 3" x 3/4" F NPT x 3/4" F NPT

4" x 4" x 3/4" F NPT x 3/4" F NPT

Features:

- Smart Connect feature
- 316 Stainless Steel
- EPDM Sealing Element
- F NPT Branch Connections



Stock Code	Dimensions
80067	2-1/2" x 2-1/2" x 3/4" F NPT x 3/4" F NPT
80069	3" x 3" x 3/4" F NPT x 3/4" F NPT
80068	4" x 4" x 3/4" F NPT x 3/4" F NPT

Special Products

Viega ProPress for stainless Di-Electric Union - Female

Application:

The Viega ProPress for 316 stainless di-electric union can be used when making connections to dissimilar metals in General Utility, Chilled Water, Hydronic Heating Water, Vacuum, and Compressed Air Systems. The Di-electric Union is equipped with the Smart Connect feature for easy identification of unpressed connections during pressure testing.

Viega ProPress for 316 stainless steel di-electric unions are available in the following sizes: 1/2", 3/4", 1", 1-1/4", 1-1/2" and 2".

Features:

- Smart Connect feature
- 316 Stainless Steel
- EPDM Sealing Element
- EPDM Union Gasket



Stock Code	Dimensions
80071	1/2"
80078	3/4"
80073	1"
80074	1-1/4"
80076	1-1/2"
80077	2"

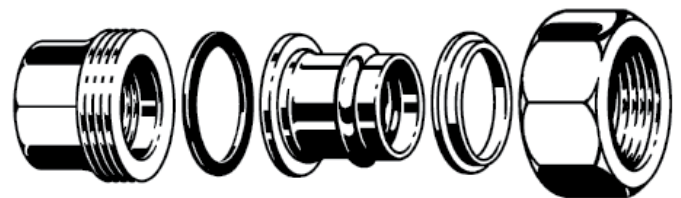

Special Products

**Viega ProPress for 304 stainless steel XL-S Adapter
Viega ProPress for 316 stainless steel XL-S Transition
Directly Connect to Existing Pipe (IPS)**



Features

- Allows easy connections to alternate piping systems
 - P x Weld
 - P x Groove
- P x Weld eliminates heat spacers

Viega, the world leader in press technology, introduces 304 and 316 stainless steel XL-S transition fittings. The Viega ProPress for stainless XL-S transition fittings allow Viega's press technology to connect directly to alternate piping systems.

One Viega ProPress for stainless XL-S transition fitting is all that's required to go directly from welded pipe connections to press pipe connections (P x Weld) or grooved pipe connections to press pipe connections (P x Groove).

Made from the finest quality 304 and 316 stainless steel, Viega ProPress for stainless XL-S transition fittings incorporate Viega's patented Smart Connect (SC) feature. The Smart Connect feature is a fast & reliable way for installers to identify un-pressed connection during testing.

Stock Code	Size	Description
85166	2-1/2"	304 Press X Groove (IPS)
85177	3"	304 Press X Groove (IPS)
85188	4"	304 Press X Groove (IPS)
80064	2-1/2"	316 Press X Groove (IPS)
80061	3"	316 Press X Groove (IPS)
80063	4"	316 Press X Groove (IPS)
85135	2-1/2"	304 Press X Weld (IPS)
85145	3"	304 Press X Weld (IPS)
85155	4"	304 Press X Weld (IPS)
80081	2-1/2"	316 Press X Weld (IPS)
80082	3"	316 Press X Weld (IPS)
80083	4"	316 Press X Weld (IPS)

Special Products

Raised Face Adapter Flange — Available in sizes 1/2", 3/4", 1", 1-1/4", 1-1/2", 2", 2-1/2", 3" and 4"

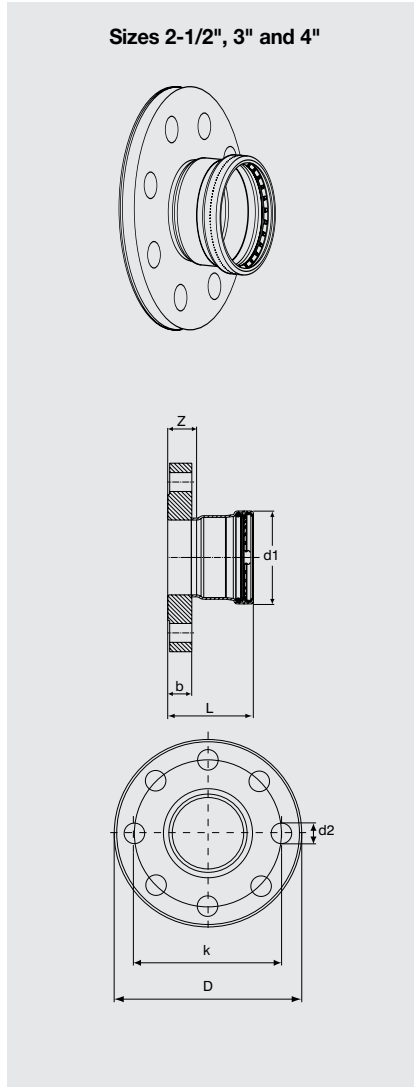
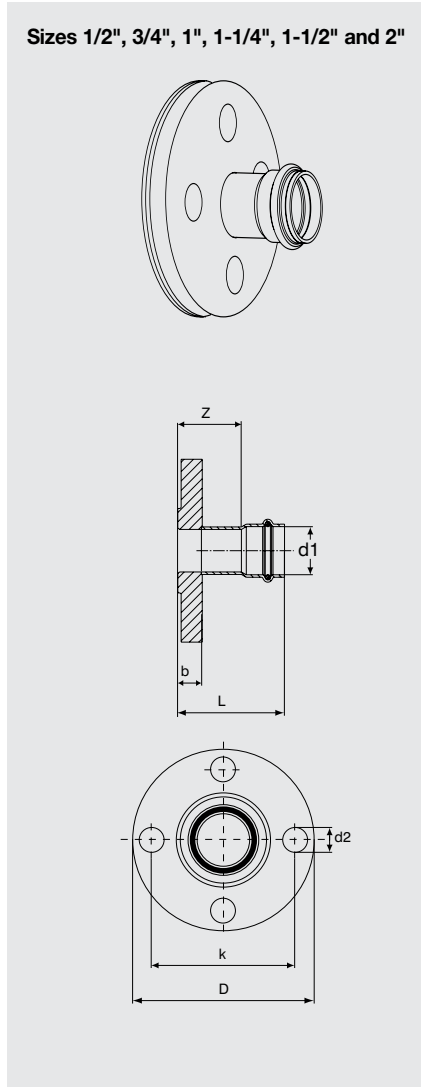

Materials & Construction

- 304 and 316 Stainless Steel
- EPDM Sealing Element
- 2-1/2"- 4" Stainless Steel Grip Ring

Design Criteria

- Flanges are manufactured to ASME B16.24 Pipe Flanges and Flanged Fittings standard
- CLASS 150

Applications

Multipurpose adapter flange for use in General Utility, Chilled and Hydronic Heating Water, Vacuum, and Compressed Air Service.

Gasket

Part #	Size
81130	1/2"
81131	3/4"
93417	1"
93422	1-1/4"
93427	1-1/2"
93432	2"
93437	2-1/2"
93442	3"
93447	4"

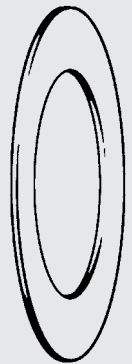

Catalog No.		Size	L	Z	b	d2	D	k
S/S 304	S/S 316	d1	(in)	(in)	(in)	(in)	(in)	(in)
86035	81035	1/2"	2.579	1.713	0.453	0.630	3.543	2.362
86040	81040	3/4"	2.579	1.673	0.512	0.630	3.937	2.756
86045	81045	1"	2.520	1.614	0.571	0.630	4.331	3.110
86050	81050	1-1/4"	2.717	1.673	0.650	0.630	4.528	3.504
86055	81055	1-1/2"	2.854	1.417	0.709	0.630	4.921	3.858
86060	81060	2"	3.878	2.303	0.768	0.748	5.906	4.764
86065	81065	2-1/2"	3.031	1.339	0.886	0.748	7.087	5.512
86070	81070	3"	3.406	1.437	0.965	0.748	7.480	5.984
86075	81075	4"	3.799	1.437	0.965	0.748	9.055	7.520

1", 1-1/4" and 1-1/2" = 1/2" bolt.
2", 2-1/2", 3" and 4" = 5/8" bolt.

Special Products

Instrumentation Adapters

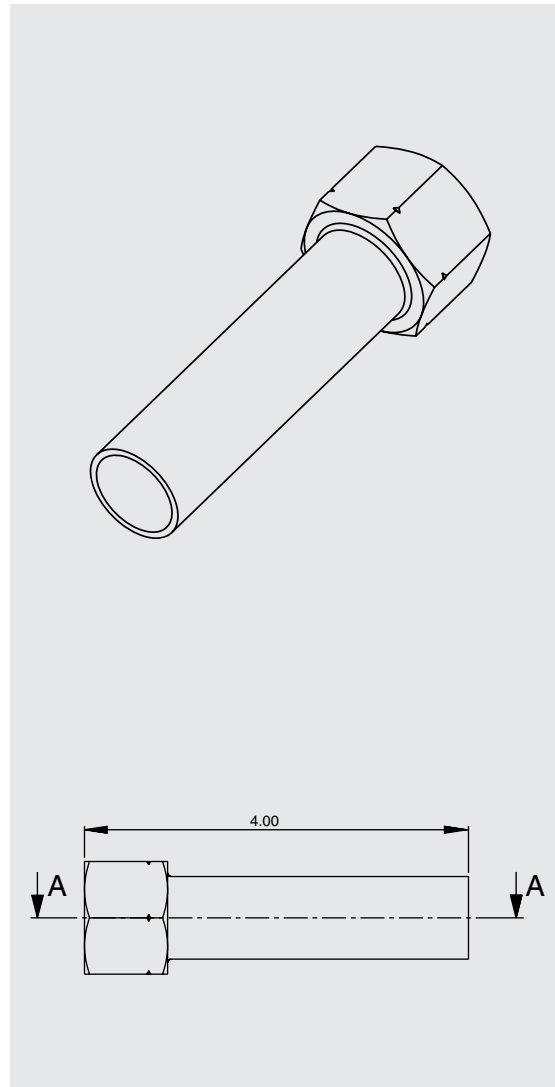
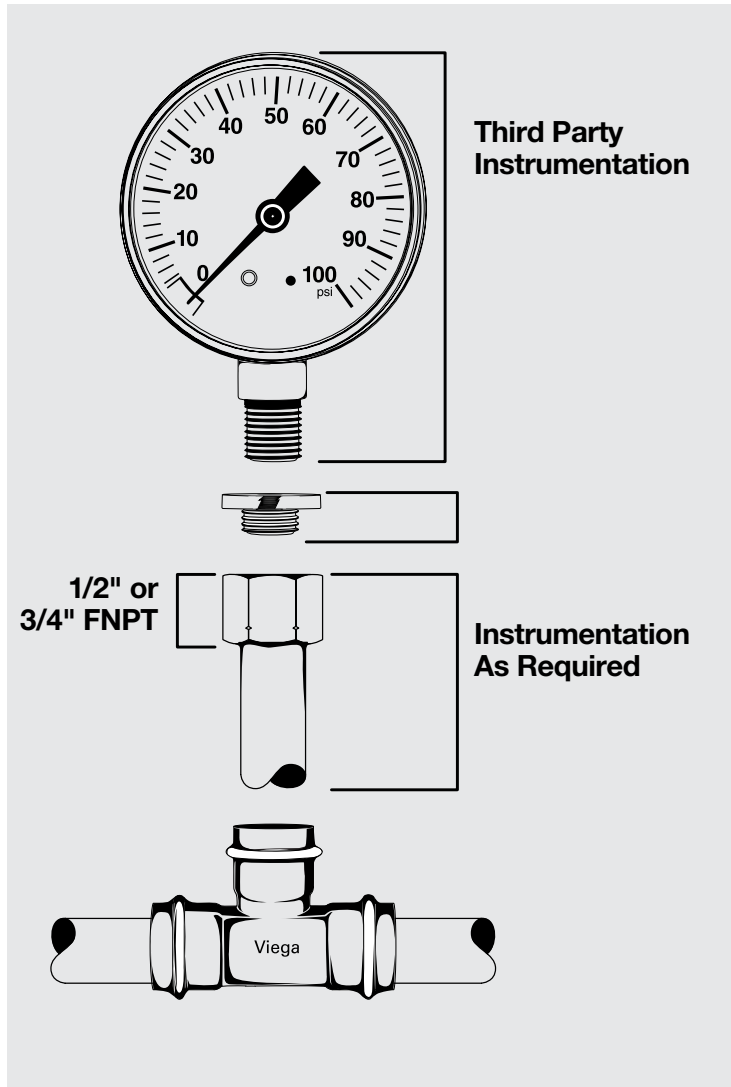

Stock Cde	Mat. #	Pipe Type	Descriptions	Model #	Size
80126	382041	316 Stainless	Instrument Adapters FTG x FNPT	40125	1/2" x 1/2"
80127	382051	316 Stainless	Instrument Adapters FTG x FNPT	40125	3/4" x 3/4"

Product Specification

Viega ProPress for 316 stainless steel Ball Valve

Application

The Viega ProPress for stainless steel ball valve is available in sizes, 1/2", 3/4", 1", 1-1/4", 1-1/2", and 2" and are equipped with the Smart Connect feature for easy identification of unpressed connections during pressure testing.

Features

- Viega ProPress press ends
- Full port, two piece design
- Blowout-proof stainless steel stem
- Reinforced PTFE seats
- 600 WOG
- Conforms to MSS SP-110
- NSF-61 Approved
- Rated 0°F - 250°F
- Lockable metal handle

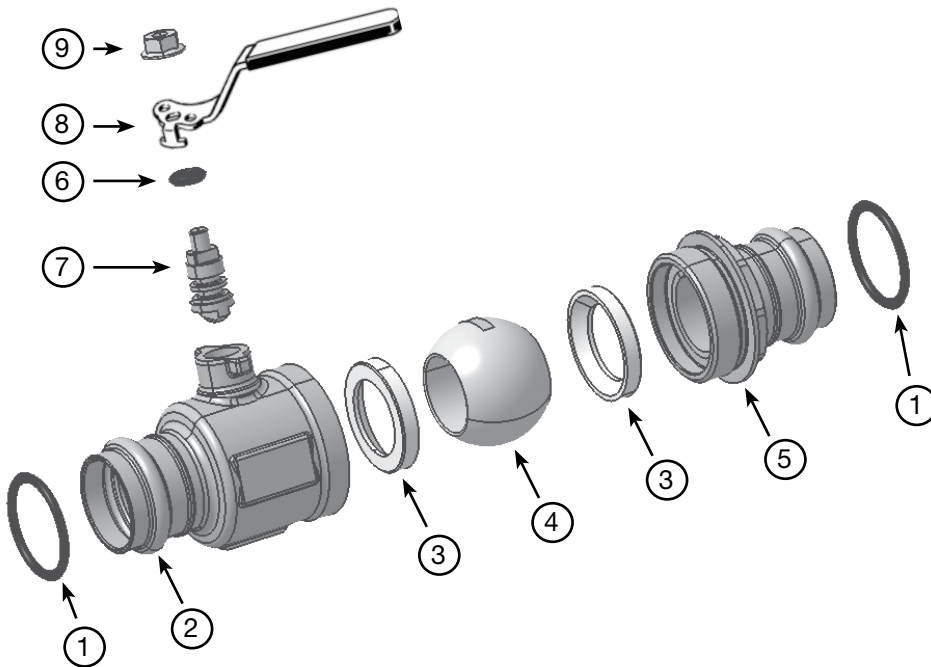
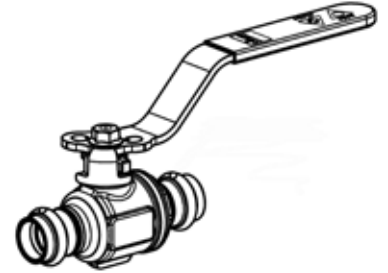

Part	Description
1	EPDM Sealing Element
2	316 Stainless Steel Valve Body End Piece
3	PTFE Seat
4	316 Stainless Steel Ball
5	316 Stainless Steel Valve Body
6	Washer
7	316 Stainless Steel Stem
8	Metal Handle w/ Sleeve (can be ordered separately)
9	Galvanized Steel Nut

	Ball Valve Torque Information			
	Turning Torque Range		1st Movement Range	
	< Nm	< lbs in	< Nm	< lbs in
1/2"	6	53	9	80
3/4"	8	71	20	177
1"	10	89	25	221
1-1/4"	15	133	32.5	288
1-1/2"	12	106	30	266
2"	21	186	47	416

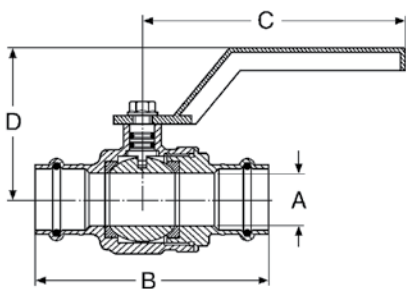

Viega ProPress Metal Handle Ball Valve - (SC) P x P					
Stock Code	Size	A	B	C	D
S/S 316	d	(in)	(in)	(in)	(in)
81080	1/2"	0.650	3.543	4.331	2.402
81085	3/4"	0.787	4.193	4.331	2.461
81090	1"	0.984	4.567	4.823	2.795
81095	1-1/4"	1.260	5.217	4.823	3.228
81100	1-1/2"	1.575	6.496	5.315	3.661
81105	2"	1.969	7.323	5.315	3.976

Frequently Asked Questions

Q: What is the Smart Connect feature?

A: The Smart Connect feature provides a quick and easy way to identify unpressed-connections during the pressure testing process. Unpressed connections are located by pressurizing the system with air or water. When testing with air, the pressure range is 1/2 psi to 85 psi maximum. The Smart Connect feature is removed during the pressing process, creating a leak-proof, permanent connection. Guaranteed.

Q: Why is the Smart Connect feature so valuable?

A: The Smart Connect feature provides the user with a strong peace of mind. It allows for faster testing procedures since you do not have to shut down and drain the system. Costly damages and possible insurance claims and premiums can be avoided because it identifies unpressed connections before they can become a problem. Because of the time savings, projects stay on track.

Q: Do I need additional equipment to install Viega ProPress for stainless?

A: No. Viega designed Viega ProPress for stainless to be compatible with the same jaws and press tools that are used for Viega ProPress and Viega ProPressG copper.

Q: If a leak is discovered, is it necessary to drain the system prior to pressing the connection?

A: No. It is not necessary to drain the system when making a repair.

Q: How would an inspector know they are looking at a good connection?

A: Good connections can be proven by performing a pressure test, using the same procedure for a fitting system.

Q: What is the lubrication used on the sealing elements?

A: The sealing elements are lubricated with an USDA approved H1 lubricant, meeting the requirement of FDA 21CFR. If it is necessary to lubricate the seals in the field, use water only. Do not use petroleum-based lubricants. Petroleum and EPDM are incompatible.

Q: How long will the EPDM seal last?

A: When properly installed, the EPDM seal and connection will last as long as the piping system.

Q: How do I fabricate a system in tight places when using Viega ProPress for stainless?

A: If necessary pre-fabricate connections that are in tight places and then install.

Q: What is the warranty for Viega ProPress for stainless fittings?

A: Viega ProPress fittings carry a 2 year warranty against defects in material and workmanship from Viega.

Q: How do Viega ProPress for stainless connections hold up to freezing temperatures?

A: Precautions should be taken for any piping system to protect the system from below freezing temperatures.

Q: What is the main cause of turbulence in Viega ProPress for stainless Steel fittings and will it cause premature wear in the piping?

A: Not reaming the ID of the pipe is the largest contributing factor to turbulence and premature wear of any piping system.

Q: What are the flow rates through Viega ProPress for stainless Steel fittings?

A: The friction loss allowance table can be found on page 38.

Frequently Asked Questions

Q: Why use FKM or HNBR sealing elements for compressed air systems with more than 25 grams per cubic foot of oil content?

A: FKM and HNBR sealing elements are better suited for high oil content due to their high resistance to hydrocarbon substances.

Q: What should a user do if a Viega ProPress for stainless system leaks?

A: In general, Viega ProPress for stainless fittings only leak due to one of three reasons; the fitting was not properly inserted or the pressing jaws were not properly aligned. If the fitting was never pressed, confirm that the tubing is properly installed and proceed with pressing. If the piping was not properly inserted, cut out the fitting and reinstalled properly. If the pressing jaws were not properly aligned, cut out the fitting and reinstall properly. If problems persist, be sure to contact Viega immediately.

Q: Is Viega ProPress for stainless compatible with the cleaning agents used to disinfect a new plumbing system?

A: Yes, however, it is recommended to contact your local District Manager or the Viega Technical Support Department for consultation.

Q: What should be done if a user accidentally cuts the fitting seal?

A: Any damaged seal must be replaced. Please note that the tolerances of the fitting socket ensure that the piping is inserted at the appropriate angle.

Q: Is Viega ProPress for stainless approved for underground use?

A: Yes. Viega ProPress for stainless can be installed underground, however, users must obtain approval from the local jurisdiction. Approval of this application is based upon performance testing conducted by NSF, which includes withstanding pressure, temperature, water hammer, bending forces, torsion, temperature variation, vibration and vacuum requirements.

Q: How should Viega ProPress for stainless Steel pipe be prepared for installation?

A: Viega ProPress for stainless steel pipe shall be cut with a wheeled pipe cutter or approved stainless steel pipe cutting tool. The pipe shall be cut square to permit proper joining with the fittings. Then, remove scale, slag, dirt and debris from inside and outside of pipe and fittings before assembly. The pipe end should be wiped clean and dry and any burrs should be removed.

Q: At what temperature will the EPDM seals begin to distort?

A: There is no detractor or distortion of the EPDM seal within the stated temperature rating of 0°F to 250°F.

Q: Does the Viega ProPress for stainless system require the use of special valves?

A: No. Users can continue using their favorite valve line by using the threaded adapters or flange adapters. However, Viega ProPress for stainless offers press connection ball valves in sizes 1/2"-2".

Viega

301 N. Main, 9th Floor
Wichita, KS 67202
Phone: 1-800-976-9819
Fax: 1-316-425-7618
www.viega.com
insidesales@viega.com

©2011, ProPress®, FostaPEX®, Seapress®, MegaPress®, MegaPressG® and Viega® are registered trademarks of Viega GmbH & Co. PureFlow®, Smart Connect®, Climate Panel®, Climate Mat®, Climate Trak®, MANABLOC®, Radiant Wizard®, S-no-Ice®, Snap Panel®, XL® and XL-C® are registered trademarks of Viega LLC. MiniBloc™, ProRadiant™, PolyAlloy™, SmartLoop™, Poly PEX Press™ and Zero Lead™ are trademarks of Viega LLC; GeoFusion™, ProPressG™ and ViegaPEX™ are trademarks of Viega GmbH & Co. K.G. RIDGID® is a registered trademark of Ridge Tool Company. LEED® is a registered trademark of USGBC.

