

# UNIVERSAL BRACKETING SYSTEM

» 523-24 SERIES

PowerBar™

## SPECIFICATION

Sioux Chief 523 Series PowerBar universal bracketing system shall be used where necessary for supporting pipe or stub outs. Bracket shall be corrosion resistant, adjust telescopically from 14"–26", and have dual fastening tabs on each end. Pilot holes for #6–#10 screws shall be provided on three sides of the bracket. System shall include screws for fastening tabs, and optional adjustable channel clamps with elastomer inserts for fastening any pipe, tube, cable, etc. System shall be approved for use with copper tube, CPVC tube, PEX/PB tube, steel pipe, CSST lines, plastic or steel conduit, and low voltage DataCom cable. System shall be UV resistant, and shall be IAPMO certified.

## INSTALLATION

Adjust bracket telescopically to desired length (bracket must have a minimum center overlap of 2"). Fasten all four tabs to building member. Slide channel clamps (if applicable) to desired location along bracket. Place conduit between clamp posts, and engage clamp bridge. Ratchet bridge of channel clamp down over both posts evenly. It is permissible to use one bracket section and fasten directly through channel.

## MATERIALS

- Brackets:** 20 gauge zinc-plated steel
- Channel clamp (black):** nylon 66, V2 flame rating
- Channel clamp (orange):** polyvinylidene fluoride (PVDF), meets ASTM E84 25/50 & UL94 V-0 flame rating
- Clamp insert:** TPE (black clamp), PVDF (orange clamp)
- Screws:** #8 × 1" Phillips, panhead, drill-tip, zinc-plated

## SAFE WORKING LOAD\*

Bracket Span	Nylon channel clamps		PVDF channel clamps		
	Safe load	Temp.	Safe load	Temp.	Safe load
14"	150 lbs.	-10°–130°F	70 lbs.	-10°–130°F	50 lbs.
17"	115 lbs.	131°–179°F	38 lbs.	131°–179°F	35 lbs.
21"	80 lbs.	180°–220°F	12 lbs.	180°–220°F	25 lbs.
24"	45 lbs.	220°F +	—	220°F +	—

\*Safe working load = one-half failure of centrally hung load

## DIMENSIONS

A: channel clamp post	1 <sup>7</sup> / <sub>8</sub> "
B: channel clamp capacity	1 <sup>1</sup> / <sub>4</sub> "–1 <sup>3</sup> / <sub>8</sub> "
C: channel clamp base	1 <sup>7</sup> / <sub>8</sub> "
D: pilot hole centerline	0.203"
E: tab length	1"
F: tab hole diameter	0.15"
G: outer/inner bracket length	14"
H: bracket height	0.529"
I: bracket width	0.602"
J: pilot hole diameter	0.1"
K: metal thickness	0.036"
L: tab screw length	1"

ITEM # SUBMITTED	_____
JOB NAME	_____
LOCATION	_____
ENGINEER	_____
CONTRACTOR	_____
PO#	_____ TAG _____

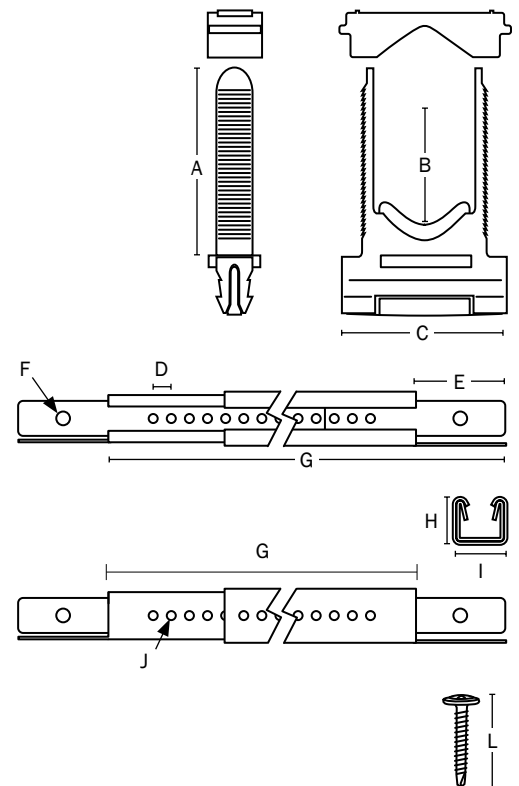

## Create Item Number

### 523A

e.g. 523-2424: 14"–26" adjustable steel bracket with two nylon channel clamps and four screws.

#### BRACKET CONFIGURATION A

- 24 = no channel clamps; no screws
- 2414 = one nylon channel clamp; four screws
- 2424 = two nylon channel clamps; four screws
- F2424 = two E84 channel clamps; four screws
- 2404 = no channel clamps; six screws
- 2434 = three nylon channel clamps; four screws