

S1, S2, S3, S5, S6, S7, S8, S12 and S13
Separators

Installation and Maintenance Instructions

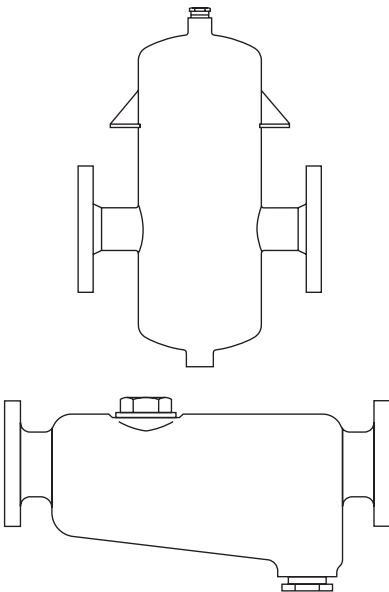

1. Safety information
2. General product information
3. Installation
4. Commissioning
5. Operation
6. Maintenance
7. Spare parts

1. Safety information

Safe operation of these products can only be guaranteed if they are properly installed, commissioned, used and maintained by qualified personnel (see Section 1.11) in compliance with the operating instructions. General installation and safety instructions for pipeline and plant construction, as well as the proper use of tools and safety equipment must also be complied with.

Warning

The inspection plug gasket on the S2, S3, S12 and S13 and the bottom cover gasket on the S5 and S6 contain a thin stainless steel support ring which may cause physical injury if not handled and disposed of carefully.

1.1 Intended use

Referring to the Installation and Maintenance Instructions, name-plate and Technical Information Sheet, check that the product is suitable for the intended use /application. The products listed below comply with the requirements of the European Pressure

Equipment Directive 97/23/EC and carry the  mark when so required.

The products fall within the following Pressure Equipment Directive categories:

Product		Group 1 Gases	Group 2 Gases	Group 1 Liquids	Group 2 Liquids
S1	16 bar g	DN15 - DN20	SEP	SEP	SEP
		DN25	2	1	SEP
S2	16 bar g	DN32 - DN40	1	SEP	SEP
		DN50	2	1	SEP
S3	16 bar g	DN40	1	SEP	SEP
		DN50 - DN80	2	1	SEP
		DN100 - DN150	3	2	2
		DN200	4	3	2
S5 and S6	50 bar g	DN15	SEP	SEP	SEP
		DN20 - DN25	2	1	SEP
		DN32 - DN50	3	2	2

Product		Group 1 Gases	Group 2 Gases	Group 1 Liquids	Group 2 Liquids	
S7 and S8	14 bar g	DN65 - DN125	3	2	2	SEP
		DN150 - DN200	4	3	2	SEP
		DN250 - DN350	4	4	2	SEP
	20 bar g and 23 bar g	DN65 - DN80	3	2	2	SEP
		DN100 - DN150	4	3	2	SEP
		DN200 - DN300	4	4	2	SEP
		DN350	4	4	2	1
	25 bar g	DN65 - DN80	3	2	2	SEP
		DN100 - DN150	4	3	2	SEP
		DN200 - DN250	4	4	2	SEP
		DN300 - DN350	4	4	2	1
	S12	25 bar g	DN32 - DN40	1	SEP	SEP
DN50			2	1	SEP	SEP
S13	25 bar g	DN40	1	SEP	SEP	SEP
		DN50 - DN80	2	1	SEP	SEP
		DN100 - DN125	3	2	2	SEP
		DN150 - DN200	4	3	2	SEP

- i) The products have been specifically designed for use on propane or methane gases which are in Group 1 of the above mentioned Pressure Equipment Directive. They can also be used on steam, air or condensate which are in Group 2 of the Pressure Equipment Directive. The products' use on other fluids may be possible but, if this is contemplated, Spirax Sarco should be contacted to confirm the suitability of the product for the application being considered.
- ii) Check material suitability, pressure and temperature and their maximum and minimum values. If the maximum operating limits of the product are lower than those of the system in which it is being fitted, or if malfunction of the product could result in a dangerous overpressure or overtemperature occurrence, ensure a safety device is included in the system to prevent such over-limit situations.

- iii) A number of products are supplied for the intention of the end user (or agent thereof) modifying the flange configuration from that supplied. It is the responsibility of the organisation carrying out the modification to do so in accordance with the internationally recognised flange standards and to ensure that the design rating and operation of the product are not compromised. Spirax Sarco will not be held responsible for any unapproved modification or consequential liability resulting in failure to observe these requirements.
- iv) Determine the correct installation situation and direction of fluid flow.
- v) Spirax Sarco products are not intended to withstand external stresses that may be induced by any system to which they are fitted. It is the responsibility of the installer to consider these stresses and take adequate precautions to minimise them.
- vi) Remove protection covers from all connections and protective film from all nameplates, where appropriate, before installation on steam or other high temperature applications.

1.2 Access

Ensure safe access and if necessary a safe working platform (suitably guarded) before attempting to work on the product. Arrange suitable lifting gear if required.

1.3 Lighting

Ensure adequate lighting, particularly where detailed or intricate work is required.

1.4 Hazardous liquids or gases in the pipeline

Consider what is in the pipeline or what may have been in the pipeline at some previous time. Consider: flammable materials, substances hazardous to health, extremes of temperature.

1.5 Hazardous environment around the product

Consider: explosion risk areas, lack of oxygen (e.g. tanks, pits), dangerous gases, extremes of temperature, hot surfaces, fire hazard (e.g. during welding), excessive noise, moving machinery.

1.6 The system

Consider the effect on the complete system of the work proposed. Will any proposed action (e.g. closing isolation valves, electrical isolation) put any other part of the system or any personnel at risk?

Dangers might include isolation of vents or protective devices or the rendering ineffective of controls or alarms. Ensure isolation valves are turned on and off in a gradual way to avoid system shocks.

1.7 Pressure systems

Ensure that any pressure is isolated and safely vented to atmospheric pressure. Consider double isolation (double block and bleed) and the locking or labelling of closed valves. Do not assume that the system has depressurised even when the pressure gauge indicates zero.

1.8 Temperature

Allow time for temperature to normalise after isolation to avoid danger of burns.

1.9 Tools and consumables

Before starting work ensure that you have suitable tools and/or consumables available. Use only genuine Spirax Sarco replacement parts.

1.10 Protective clothing

Consider whether you and/or others in the vicinity require any protective clothing to protect against the hazards of, for example, chemicals, high/low temperature, radiation, noise, falling objects, and dangers to eyes and face.

1.11 Permits to work

All work must be carried out or be supervised by a suitably competent person. Installation and operating personnel should be trained in the correct use of the product according to the Installation and Maintenance Instructions. Where a formal 'permit to work' system is in force it must be complied with. Where there is no such system, it is recommended that a responsible person should know what work is going on and, where necessary, arrange to have an assistant whose primary responsibility is safety. Post 'warning notices' if necessary.

1.12 Handling

Manual handling of large and/or heavy products may present a risk of injury. Lifting, pushing, pulling, carrying or supporting a load by bodily force can cause injury particularly to the back. You are advised to assess the risks taking into account the task, the individual, the load and the working environment and use the appropriate handling method depending on the circumstances of the work being done.

1.13 Residual hazards

In normal use the external surface of the product may be very hot. If used at the maximum permitted operating conditions the surface temperature of some products may reach temperatures of 300 °C (572 °F).

Many products are not self-draining. Take due care when dismantling or removing the product from an installation (refer to Section 6 'Maintenance instructions').

1.14 Freezing

Provision must be made to protect products which are not self-draining against frost damage in environments where they may be exposed to temperatures below freezing point.

1.15 Disposal

Unless otherwise stated in the Installation and Maintenance Instructions, this product is recyclable and no ecological hazard is anticipated with its disposal providing due care is taken.

1.16 Returning products

Customers and stockists are reminded that under EC Health, Safety and Environment Law, when returning products to Spirax Sarco they must provide information on any hazards and the precautions to be taken due to contamination residues or mechanical damage which may present a health, safety or environmental risk. This information must be provided in writing including Health and Safety data sheets relating to any substances identified as hazardous or potentially hazardous.

1.17 Working safely with cast iron products on steam

Cast iron products are commonly found on steam and condensate systems. If installed correctly using good steam engineering practices, it is perfectly safe. However, because of its mechanical properties, it is less forgiving compared to other materials such as SG iron or carbon steel. The following are the good engineering practices required to prevent waterhammer and ensure safe working conditions on a steam system.

Safe Handling

Cast Iron is a brittle material. If the product is dropped during installation and there is any risk of damage the product should not be used unless it is fully inspected and pressure tested by the manufacturer.

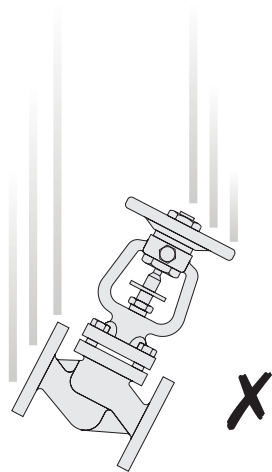

Prevention of water hammer

Steam trapping on steam mains:

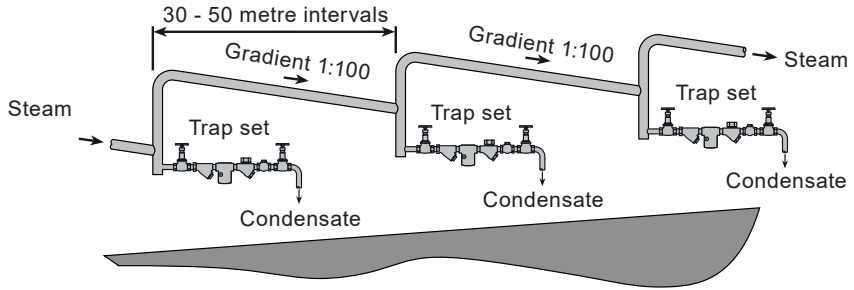

Steam Mains - Do's and Don'ts:

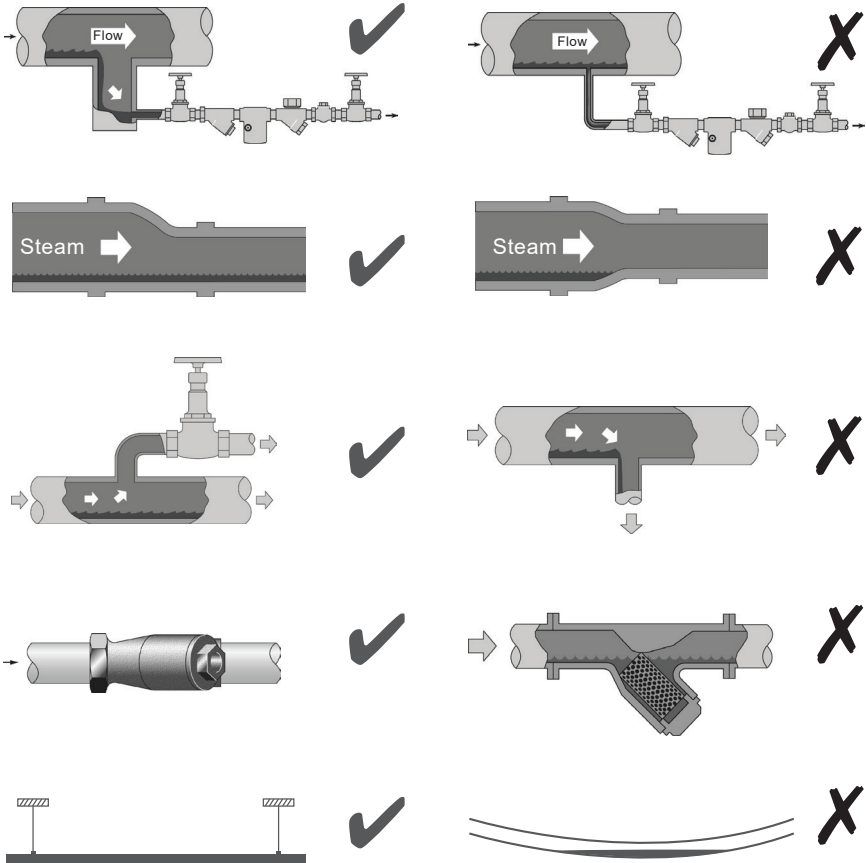

Prevention of tensile stressing

Pipe misalignment:

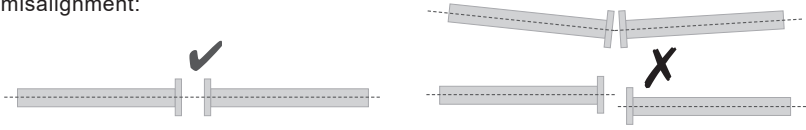

Installing products or re-assembling after maintenance:

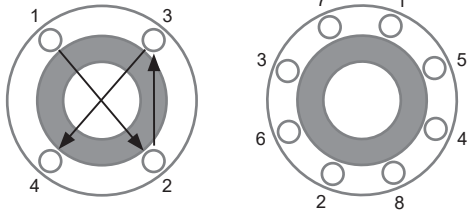

Do not over tighten.
Use correct torque figures.

Flange bolts should be gradually tightened across diameters to ensure even load and alignment.

Thermal expansion:

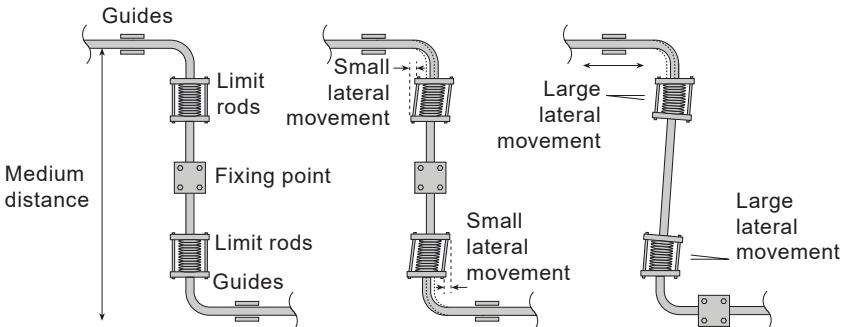
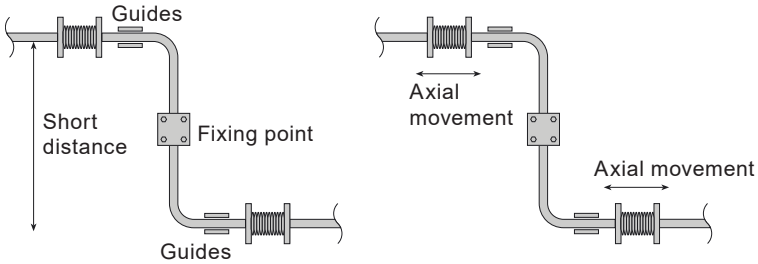

2. General product information

2.1 General description

The products detailed are all baffle type separators used for the removal of entrained liquids in steam, compressed air and gas systems. We recommend the fitting of insulating jackets to improve the performance of the separator.

Note: For additional product data see the following Technical Information Sheets.

Type	Material	Pressure rating	Sizes	Connections	TI reference
S1	SG iron	PN16	½", ¾" and 1"	Screwed	TI-P023-02
S2	Cast iron	PN16	1¼", 1½" and 2"	Screwed	TI-P023-07
S3	Cast iron	PN16	DN40 - DN200	Flanged	TI-P023-24
S5	Carbon steel	PN50/ASME 300	DN15 - DN50	Screwed and Flanged	TI-P023-11
S6	Austenitic stainless steel 316L	PN50/ASME 300	DN15 - DN50	Screwed and Flanged	TI-P023-12
S7*	Carbon steel	PN16 and PN40	DN65 - DN350	Flanged	TI-P138-03
S8*	Austenitic stainless	PN16 and PN40	DN65 - DN350	Flanged	TI-P138-10
S12	SG iron	PN25	1¼", 1½" and 2"	Screwed	TI-P023-25
S13	SG iron	PN25	DN40 - DN200	Flanged	TI-P023-26

* **Note:** The S7 and S8 separators are designed and manufactured to PD 5500 Category 3.

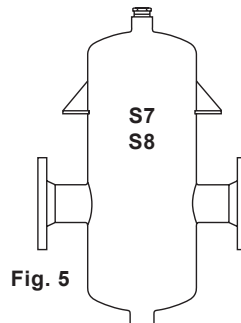
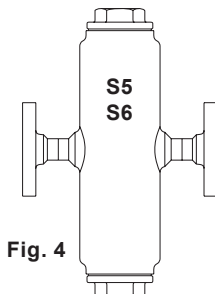
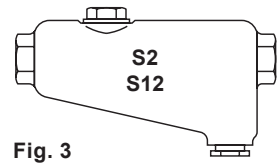
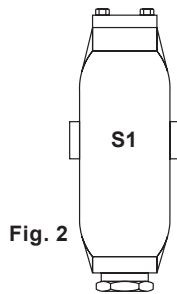
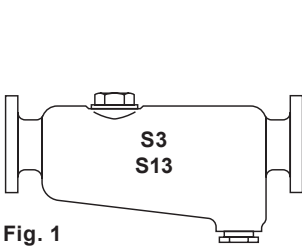

2.2 Pressure/temperature limits

Type	S1	S2	S3	S5	S6	S7	S8	S12	S13
See Section	2.2.1	2.2.2	2.2.2	2.2.3	2.2.4	2.2.5	2.2.6	2.2.7	2.2.8

2.2.1 S1 pressure / temperature limits (ISO 6552)

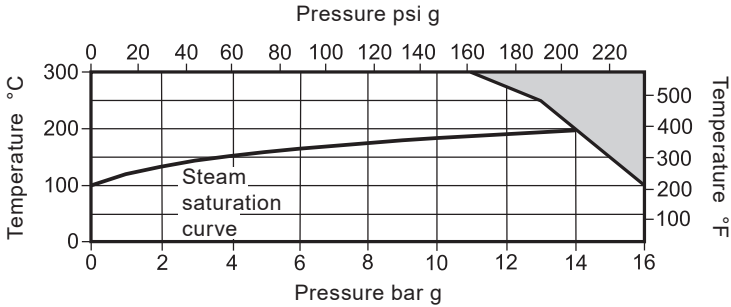

 The product **must not** be used in this region.

Body design conditions	PN16		
PMA	Maximum allowable pressure	16 bar g @ 100 °C (232 psi g @ 212 °F)	
TMA	Maximum allowable temperature	300 °C @ 11 bar g (512 °F @ 232 psi g)	
	Minimum allowable temperature	0 °C (32 °F)	
PMO	Maximum operating pressure for saturated steam service	13.8 bar g (188 psi g)	
TMO	Maximum operating temperature	200 °C @ 13.8 bar g (392 °F @ 203 psi g)	
	Minimum operating temperature	0 °C (32 °F)	
Note: For lower operating temperatures consult Spirax Sarco.			
	Designed for a maximum cold hydraulic test pressure of:	24 bar g (348 psi g)	

2.2.2 S2 and S3 pressure/temperature limits (ISO 6552)

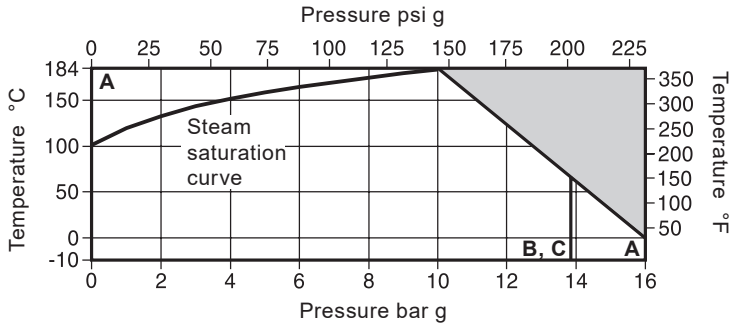

The product **must not** be used in this region.

A - A Flanged EN 1092 PN16, Table F and screwed BSP or NPT.

A - B Flanged JIS/KS 10K.

A - C Flanged ASME Class 125.

Body design conditions		PN16
PMA	Maximum allowable pressure	16 bar g @ 0 °C (232 psi g @ 32 °F)
TMA	Maximum allowable temperature	184 °C @ 10 bar g (363 °F @ 145 psi g)
Minimum allowable temperature		-10 °C (14 °F)
PMO	Maximum operating pressure for saturated steam service	10 bar g (145 psi g)
TMO	Maximum operating temperature	184 °C @ 10 bar g (363 °F @ 145 psi g)
Minimum operating temperature		-10 °C (14 °F)
Note: For lower operating temperatures consult Spirax Sarco.		
Designed for a maximum cold hydraulic test pressure of:		24 bar g (348 psi g)

Note: Flanged separators (S3) may be supplied with a lower pressure rating than that cast into the body. Reference should be made to the appropriate operating chart to determine the actual product limitations.

2.2.3 S5 pressure/temperature limits (ISO 6552)

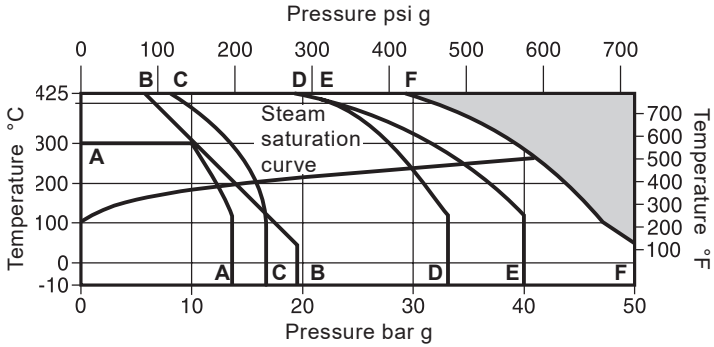

The product **must not** be used in this region.

A - A Flanged JIS / KS 10K.

B - B Flanged ASME Class 150.

C - C Flanged EN 1092 PN16.

D - D Flanged JIS / KS 20K.

E - E Flanged EN 1092 PN40.

F - F Screwed BSP, NPT, socket weld and butt weld.

Body design conditions		PN50 or ASME 300	
PMA	Maximum allowable pressure	50 bar g @ 50 °C (725 psi g @ 122 °F)	
TMA	Maximum allowable temperature	425 °C @ 28 bar g (797 °F @ 406 psi g)	
Minimum allowable temperature		-10 °C	(14 °F)
PMO	Maximum operating pressure for saturated steam service	JIS/KS 10K	12.5 bar g (181 psi g)
		PN16	13.8 bar g (200 psi g)
		ASME 150	15.0 bar g (217 psi g)
		JIS/KS 10K	30.0 bar g (435 psi g)
		PN40	35.9 bar g (520 psi g)
		ASME 300	41.4 bar g (600 psi g)
		Scrd/SW/BW	41.4 bar g (600 psi g)
TMO	Maximum operating temperature	425 °C @ 28 bar g (797 °F @ 406 psi g)	
Minimum operating temperature		-10 °C	(14 °F)
Note: For lower operating temperatures consult Spirax Sarco.			
Designed for a maximum cold hydraulic test pressure of:	JIS/KS 10K	20.6 bar g	(299 psi g)
	PN16	24.0 bar g	(348 psi g)
	ASME 150	30.0 bar g	(435 psi g)
	JIS/KS 10K	50.0 bar g	(725 psi g)
	PN40	60.0 bar g	(870 psi g)
	ASME 300	76.6 bar g	(1 111 psi g)
	Scrd/SW/BW	76.6 bar g	(1 111 psi g)

Note: Flanged separators (S5) may be supplied with a lower pressure rating than that cast into the body. Reference should be made to the appropriate operating chart to determine the actual product limitations.

2.2.4 S6 pressure/temperature limits (ISO 6552)

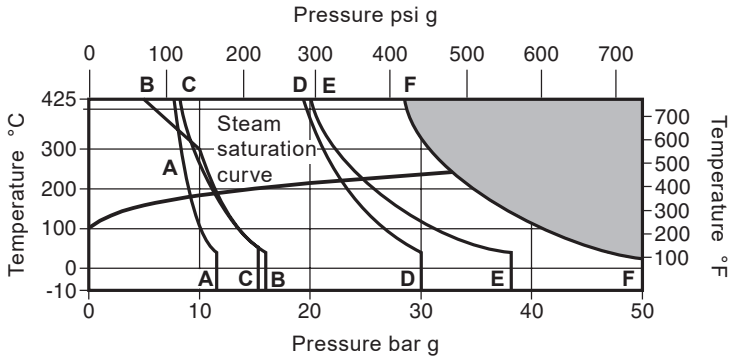

 The product **must not** be used in this region.

- A - A** Flanged JIS/KS 10K.
- B - B** Flanged ASME Class 150.
- C - C** Flanged EN 1092 PN16.
- D - D** Flanged JIS/KS 20K.
- E - E** Flanged EN 1092 PN40.
- F - F** Flanged ASME Class 150 screwed BSP, NPT, socket weld and butt weld.

Body design conditions		PN50 or ASME 300	
PMA	Maximum allowable pressure	50 bar g @ 50 °C (725 psi g @ 122 °F)	
TMA	Maximum allowable temperature	425 °C @ 28 bar g (797 °F @ 406 psi g)	
Minimum allowable temperature		-10 °C	(14 °F)
PMO	Maximum operating pressure for saturated steam service	JIS/KS 10K	9.9 bar g (143 psi g)
		PN16	11.4 bar g (165 psi g)
		ASME 150	11.4 bar g (165 psi g)
		JIS/KS 10K	23.5 bar g (341 psi g)
		PN40	25.8 bar g (374 psi g)
		ASME 300	34.1 bar g (494 psi g)
		Scrd/SW/BW	34.1 bar g (494 psi g)
TMO	Maximum operating temperature	425 °C @ 28 bar g (797 °F @ 406 psi g)	
Minimum operating temperature		-10 °C	(14 °F)
Note: For lower operating temperatures consult Spirax Sarco.			
Designed for a maximum cold hydraulic test pressure of:	JIS/KS 10K	20.6 bar g	(299 psi g)
	PN16	24.0 bar g	(348 psi g)
	ASME 150	30.0 bar g	(435 psi g)
	JIS/KS 10K	50.0 bar g	(725 psi g)
	PN40	60.0 bar g	(870 psi g)
	ASME 300	76.6 bar g	(1 111 psi g)
	Scrd/SW/BW	76.6 bar g	(1 111 psi g)

Note: Flanged separators (S6) may be supplied with a lower pressure rating than that cast into the body. Reference should be made to the appropriate operating chart to determine the actual product limitations.

2.2.5 S7 pressure/temperature limits (ISO 6552)

Size	Flange standard	Design pressure		Design temperature		Designed for a maximum cold hydraulic test pressure of:	
		bar g	psi g	°C	°F	bar g	psi g
DN65 to DN350	PN16	14	203	198	388	21	304
	ASME 150	20	290	213	415	30	435
	JIS/KS 20K	23	333	217	422	34.5	500
	PN40	25	362	225	455	37.5	544
	ASME 300	25	362	225	455	37.5	544

For pressures and temperatures that exceed these operating conditions please contact Spirax Sarco for a quotation.

2.2.6 S8 pressure/temperature limits (ISO 6552)

Size	Flange standard	Design pressure		Design temperature		Designed for a maximum cold hydraulic test pressure of:	
		bar g	psi g	°C	°F	bar g	psi g
DN65 to DN350	PN16	14	203	198	388	21	304
	ASME 150	20	290	213	415	30	435
	JIS/KS 20K	23	333	217	422	34.5	500
	PN40	25	362	225	455	37.5	544
	ASME 300	25	362	225	455	37.5	544

For pressures and temperatures that exceed these operating conditions please contact Spirax Sarco for a quotation.

2.2.7 S12 pressure/temperature limits (ISO 6552)

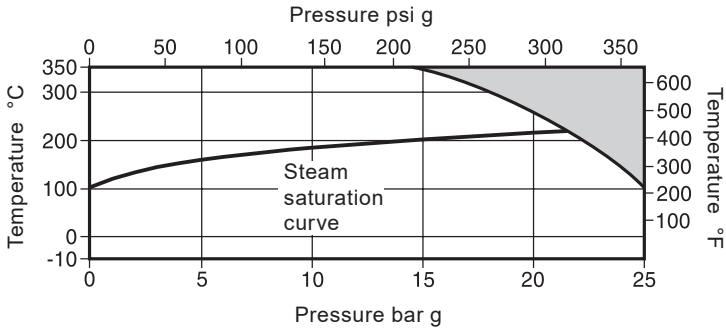

The product **must not** be used in this region.

Body design conditions		PN25
PMA	Maximum allowable pressure	25 bar g @ 100 °C (362 psi g @ 212 °F)
TMA	Maximum allowable temperature	350 °C @ 14 bar g (662 °F @ 203 psi g)
Minimum allowable temperature		-10 °C (14 °F)
PMO	Maximum operating pressure for saturated steam service	21.3 bar g (309 psi g)
TMO	Maximum operating temperature	350 °C @ 14 bar g (662 °F @ 203 psi g)
Minimum operating temperature		-10 °C (14 °F)
Note: For lower operating temperatures consult Spirax Sarco.		
Designed for a maximum cold hydraulic test pressure of:		38 bar g (551 psi g)

2.2.8 S13 pressure/temperature limits (ISO 6552)

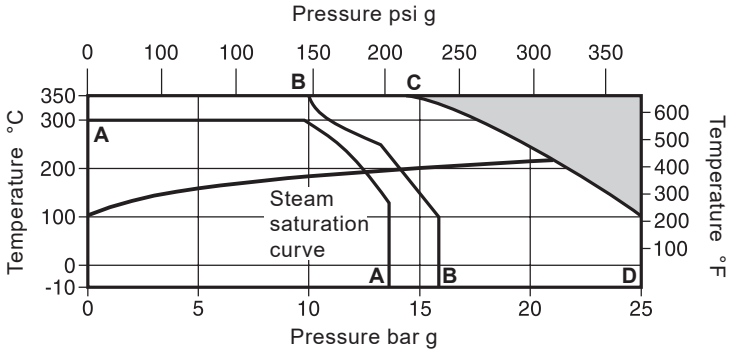

 The product **must not** be used in this region.

- A - A** Flanged JIS / KS 10K.
- B - B** Flanged EN 1092 PN16.
- B - C - D** Flanged EN 1092 PN25 and JIS 20K.

Body design conditions		PN25	
PMA	Maximum allowable pressure	25 bar g @ 100 °C (632 psi g @ 212 °F)	
TMA	Maximum allowable temperature	350 °C @ 14 bar g (662 °F @ 203 psi g)	
Minimum allowable temperature		-10 °C	(14 °F)
PMO	Maximum operating pressure for saturated steam service	JIS / KS 10K	12.3 bar g (178 psi g)
		PN16	13.7 bar g (198 psi g)
		JIS / KS 20K	21.3 bar g (309 psi g)
		PN25	21.3 bar g (309 psi g)
TMO	Maximum operating temperature	350 °C @ 14 bar g (662 °F @ 203 psi g)	
Minimum operating temperature		-10 °C	(14 °F)
Note: For lower operating temperatures consult Spirax Sarco.			
Designed for a maximum cold hydraulic test pressure of:	JIS / KS 10K	20.4 bar g	(296 psi g)
	PN16	24.0 bar g	(348 psi g)
	PN25	37.5 bar g	(544 psi g)
	JIS / KS 20K	37.5 bar g	(544 psi g)

Note: Flanged separators (S13) may be supplied with a lower pressure rating than that cast into the body. Reference should be made to the appropriate operating chart to determine the actual product limitations.

2.3 Markings specifications

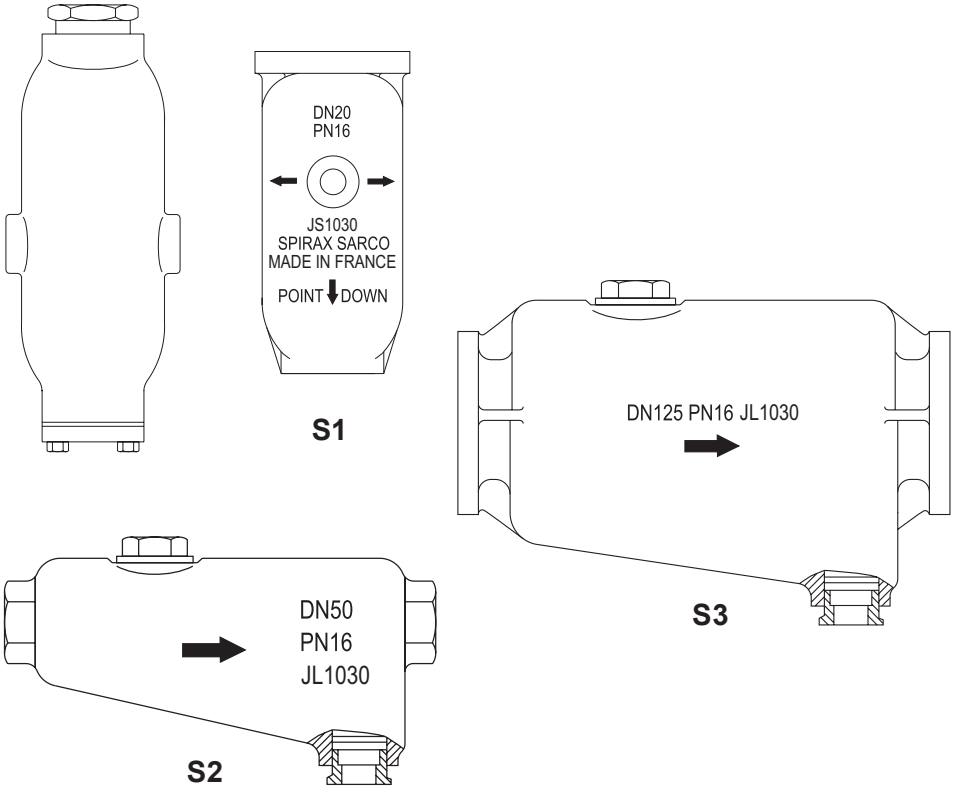

Separator	Part	Material					
		Body				Cover air	
	A	B	C	D	E	F	G
S1	S1	ASME 125	JS1030		PN16	JS1030	
S2	S2	ASME 125	A126 CI B		PN16		
S3	S3	ASME 125	A126 CI B		PN16		
S5	S5	ASME 300	WCB	1.0619+N	PN50	1.0460	A105N
S6	S6	ASME 300	CP3M	1.4404	PN50	1.4404	316L
S12	S12		A395	JS1030	PN25	1.0460 (2" only)	C22.8 (2" only)
S13	S13		A395	JS1030	PN25	1.0460	C22.8

S5 DN32 CE 0038	
PN40 - ASME 300	
1.0619+N - A216WCB	
spirax /sarco	Made in France

S5

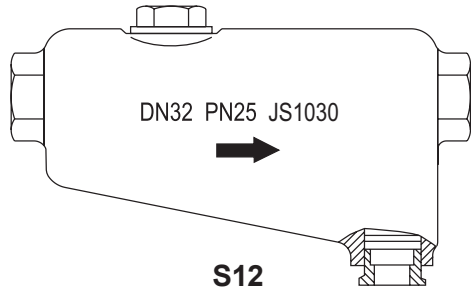

S12

S6 DN32 CE 0038	
PN40 - ASME 300	
1.4404 - CF3M	
spirax /sarco	Made in France

S6

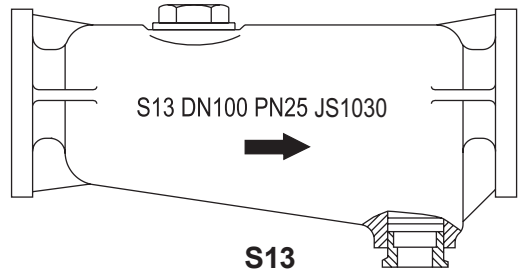

S13

Cover drain		CE marking		Made in France	SPIRAX SARCO or SXS or SPIRAX	DN
H	I	CE	CE0038			
		J		K	L	M
A105N			DN25	•	•	•
		DN32 to DN40	DN50	•	•	•
		DN40	DN50 to DN200	•	•	•
		DN15	DN20 to DN50	•	•	•
				•	•	•
A105		DN32 to DN40	DN50	•	•	•
		DN40	DN50 - DN200	•	•	•

3. Installation

Note: Before actioning any installation observe the 'Safety Information' in Section 1.

Referring to the Installation and Maintenance Instructions, body markings, name-plate (if fitted) and Technical Information Sheet, check that the product is suitable for the intended installation.

- 3.1** Check materials, pressure and temperature and their maximum values. If the maximum operating limit of the product is lower than that of the system in which it is being fitted, ensure a safety device is included in the system to prevent overpressurisation.
- 3.2** Determine the correct installation situation and the direction of fluid flow.
- 3.3** Remove protective covers from all connections and the protective film from all name-plates, where appropriate, before installation on steam or other high temperature applications.
- 3.4** The separators may be lagged if required.

Important installation note for the S1, S2, S3, S12 and S13 separators:

Install in a horizontal pipeline with the drain directly below. To ensure that any separated liquid is drained away quickly, a suitable liquid drainer or steam trap must be connected to the drain.

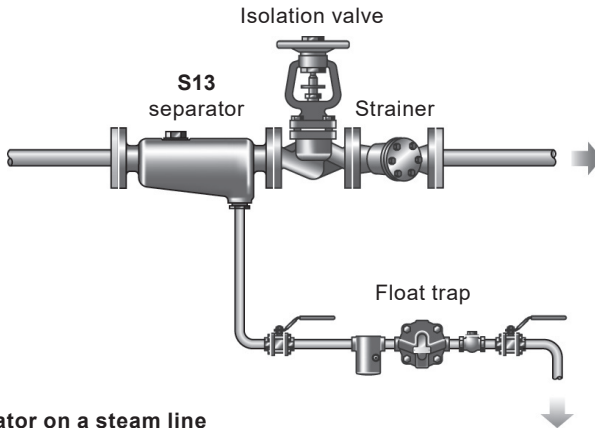

Fig. 6 Separator on a steam line

3.5 Installation for the S5 and S6

Install in a horizontal pipeline with the drain directly below.

To ensure that any separated liquid is drained quickly, a suitable liquid drainer or steam trap must be connected to the drain connection. A float type trap is recommended.

For those steam systems where air can be present, air can collect in the upper portion of the separator. In this situation a suitable air vent should be connected to the air vent connection. If an air vent is not being fitted then the connection must have the plastic transit protection plug removed and must have a carbon steel class 3000 lb plug fitted.

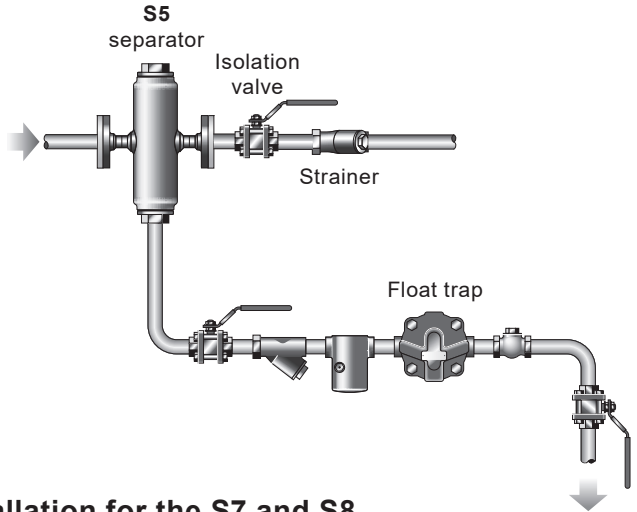

Fig. 7

3.6 Installation for the S7 and S8

Install in a horizontal pipeline with the drain directly below. All sizes are fitted with support brackets which can be used to minimise piping loads. To ensure that any separated liquid is drained quickly, a suitable liquid drainer or steam trap must always be connected to the drain connection. A float type trap is recommended. For those steam systems where air can be present, air can collect in the upper portion of the separator. In this situation a suitable air vent should be connected to the air vent connection. If an air vent is not being fitted then the connection must have the plastic transit protection plug removed and a carbon steel class 3000 lb plug fitted.

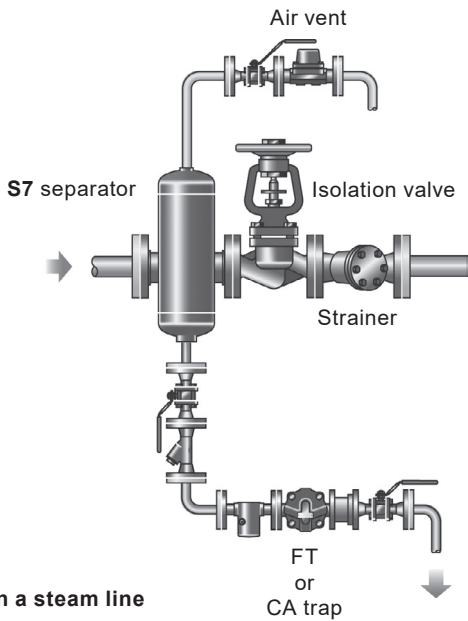

Fig. 8 Separator on a steam line

4. Commissioning

After installation or maintenance, ensure that the system is fully functioning. Carry out tests on any alarms or protective devices.

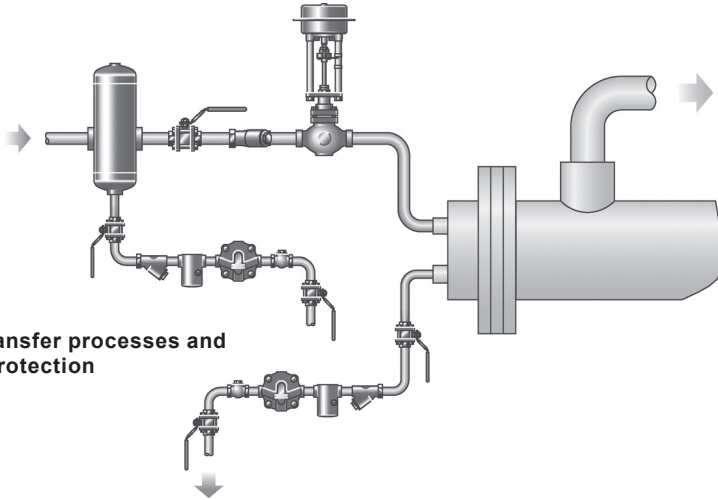

Fig. 9
Heat transfer processes and valve protection

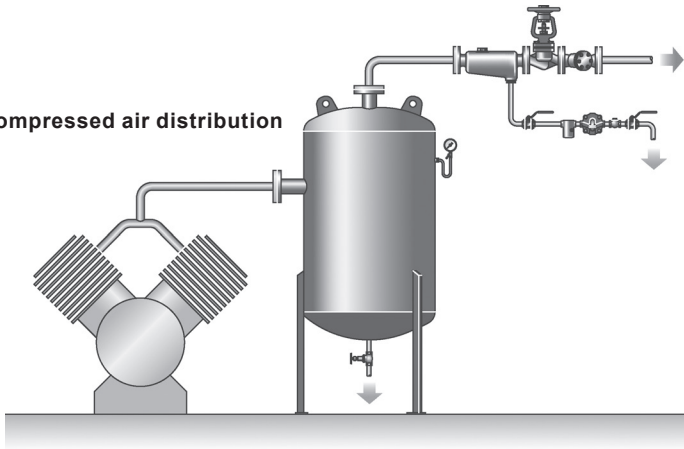

Fig. 10 Compressed air distribution

5. Operation

Separators are designed to gather together small droplets of entrained liquids and then separate them from the gas/vapour flow. The relatively heavy droplets impinge on the internal baffles and are then directed to the separator drain connection and removed from the system using a steam trap, or when used on air or gas distribution system, a liquid drainer.

6. Maintenance

Note: Before actioning any maintenance programme observe the 'Safety information' in Section 1.

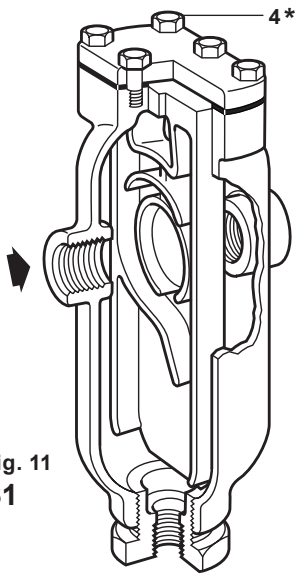

Fig. 11
S1

Warning There are no internal components that require maintenance.

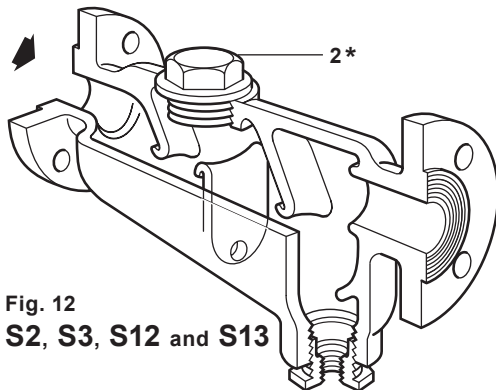



Fig. 12
S2, S3, S12 and S13

Table 1 Recommended tightening torques

Separator	Item	Size		or mm		N m	(lbf ft)
S1	4	1/2"	7/16"	1/4" UNF x 3/4"	12 - 14	(9 - 10)	
		3/4"	1/2"	5/16" UNF x 3/4"	28 - 32	(21 - 24)	
		1"	9/16"	3/8" UNF x 3/4"	40 - 50	(30 - 37)	
S2	2	2"	60 A/F	M72	190 - 210	(140 - 155)	
S3	2	DN40	46 A/F	M56	150 - 165	(110 - 121)	
		DN50	60 A/F	M72	190 - 210	(140 - 155)	
		DN65	46 A/F	M56	150 - 165	(110 - 121)	
		DN80	60 A/F	M72	190 - 210	(140 - 155)	
		DN100	60 A/F	M72	190 - 210	(140 - 155)	
		DN125	60 A/F	M72	190 - 210	(140 - 155)	
		DN150	60 A/F	M72	190 - 210	(140 - 155)	
S12	2	2"	46 A/F	M56	150 - 165	(110 - 121)	
S13	2	DN40	46 A/F	M56	150 - 165	(110 - 121)	
		DN50	46 A/F	M56	150 - 165	(110 - 121)	
		DN65	46 A/F	M56	150 - 165	(110 - 121)	
		DN80	60 A/F	M72	190 - 210	(140 - 155)	
		DN100	60 A/F	M72	190 - 210	(140 - 155)	
		DN125	60 A/F	M72	190 - 210	(140 - 155)	
		DN150	60 A/F	M72	190 - 210	(140 - 155)	
DN200	60 A/F	M72	190 - 210	(140 - 155)			

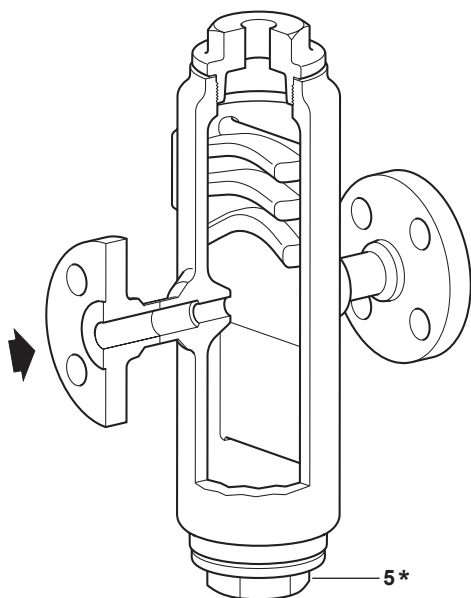

Fig. 13
S5 and S6

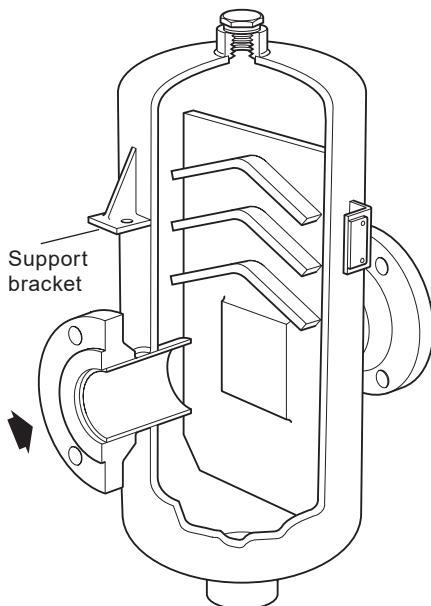



Fig. 14
S7 and S8

Table 1 Recommended tightening torques

Separator	Item	Size		N m	(lbf ft)
S5 S6	5	DN15 - DN50	46 A/F	180 - 200	133 - 150)

7. Spare parts

There are no spare parts required or available for these components.

