

# spirax sarco

## APT14, APT14HC and APT14SHC Automatic Pump Traps



### Description

The Spirax Sarco automatic pump trap is a flanged or screwed displacement receiver pressure rated to PN16. The unit is capable of automatically trapping or pumping, depending on pipeline conditions. The unit is operated by steam and is used to remove condensate from process plant under all operating conditions including vacuum. Recommended for use with motive steam only.

### Design compliance

The shell of the product has been designed in accordance with A.D. Merkblätter/ASME VIII.

### Standards

These products fully comply with the requirements of the European Pressure Equipment Directive 97/23/EC, ATEX Directive 94/9/EC and carry the  and  marks when so required.

### Certification

These products are available with certification to EN 10204 3.1. **Note:** All certification/inspection requirements must be stated at the time of order placement.

### Sizes and pipe connections

Model and body material	Inlet and outlet sizes and pipe connections		Motive/exhaust		
APT14 SG iron	Flanged	1-1/2" inlet x 1" outlet	ANSI 150 B 16.5	NPT	1/2" (DN15)
			EN 1092 PN16	NPT or BSP	1/2" (DN15)
APT14HC SG iron	Screwed	1-1/2" inlet x 1" outlet	NPT	NPT	1/2" (DN15)
			BSP (BS 21 parallel)	BSP	1/2" (DN15)
APT14SHC Carbon Steel	Flanged	2" inlet x 1-1/2" outlet	ANSI 150 B 16.5	NPT	1/2" (DN15)
			EN 1092 PN16	BSP	1/2" (DN15)
APT14SHC Carbon Steel	Flanged	2" inlet x 1-1/2" outlet	ANSI 150 B 16.5	NPT	1/2" (DN15)
			EN 1092 PN16	BSP	1/2" (DN15)

### Optional extra

Both the APT14 and APT14HC are available with the body and cover coated with electroless nickel plate (ENP). This option, when required, will be denoted as APT14 ENP and APT14HC ENP respectively and must be stated at the time of order placement.

Gauge glasses, supplied separately, are available. For further details contact Spirax Sarco.

### Dimensions/weight (approximate) in inches and pounds (mm and kg)

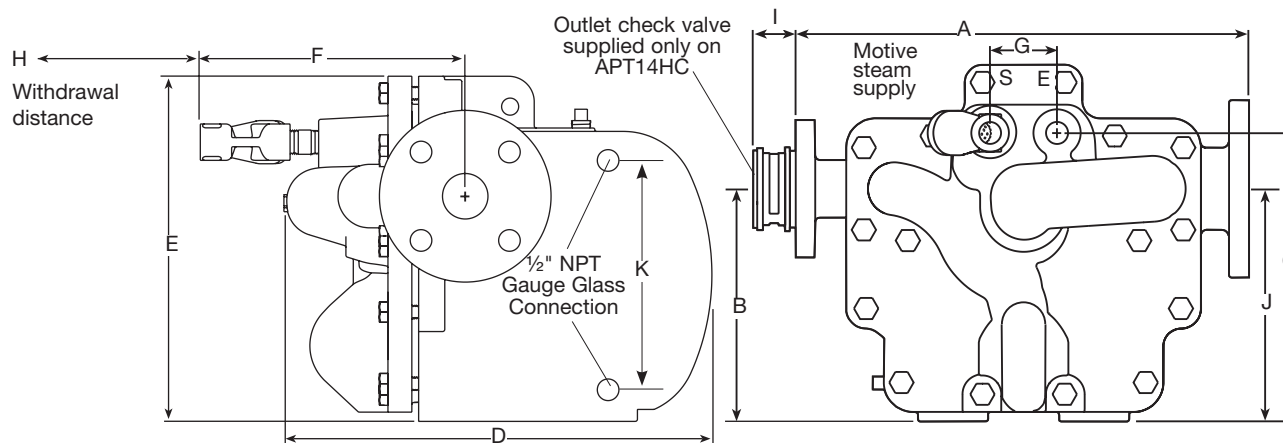



Model	Connection	A	B	C	D	E	F	G	H	PN16		J	K	Weight
										ANSI	ANSI			
APT14	Screwed	13.8 (350)	7.8 (198)	9.7 (246)	15.2 (385)	12.0 (304)	10.2 (258)	2.2 (57)	9.8 (250)	-	-	7.8 (198)	-	99 (45)
	Flanged	15.3 (389)	7.8 (198)	9.7 (246)	15.2 (385)	12.0 (304)	10.2 (258)	2.2 (57)	9.8 (250)	-	-	7.8 (198)	-	99 (45)
APT14HC	Flanged	18.7 (476)	7.8 (198)	10.6 (270)	15.7 (400)	13.2 (335)	9.3 (235)	2.2 (57)	10.8 (275)	1.2 (31.5)	1.8 (45)	7.8 (198)	9.3 (235)	143 (65)
APT14SHC	Flanged	20.0 (508)	8.1 (206)	10.9 (278)	16.0 (407)	13.8 (351)	10.3 (261)	2.2 (57)	10.8 (275)	1.2 (31.5)	1.8 (45)	7.8 (198)	9.3 (235)	232 (105)

Local regulation may restrict the use of this product below the conditions quoted. Limiting conditions refer to standard connections only.  
In the interests of development and improvement of the product, we reserve the right to change the specification.

TI-5-228-US 4.17

# APT14 and APT14HC Automatic Pump Trap

## Pressure / temperature limits

-  The product must not be used in this region.
-  The product should not be used in this region or beyond its operating range as damage to the internals may occur.
- A - D Flanged PN16.
- B - D Flanged JIS/KS 10.
- C - D Flanged ANSI 150.

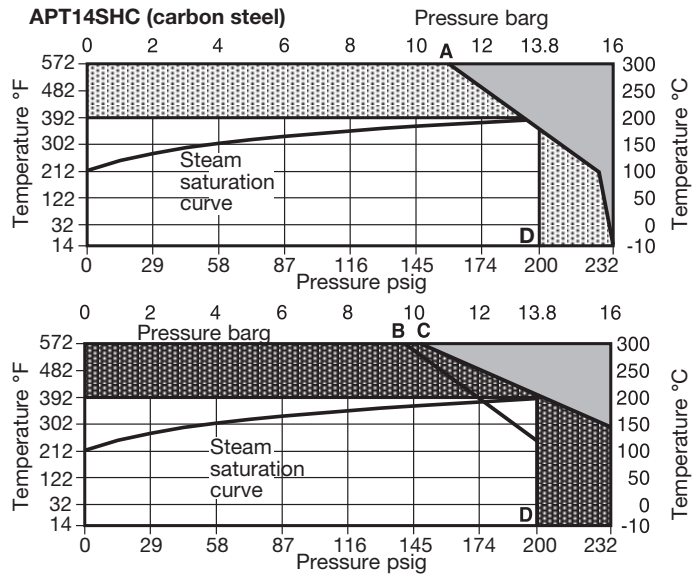
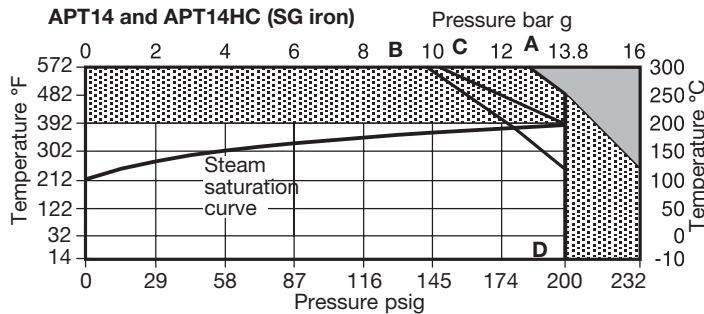

Body design conditions	PN16	
Maximum motive inlet pressure	200 psig (13.8 bar g)	
PMA Maximum allowable pressure	232 psig @ 248°F (16 bar g @ 120°C)	
TMA Maximum allowable temperature	572°F @ 185 psig (300°C @ 12.8 bar g)	
Minimum allowable temperature	14°F (-10°C)	
<b>Note:</b> For lower temperatures consult Spirax Sarco.		
PMO Maximum operating pressure for saturated steam service	200 psig @ 388°F (13.8 bar g @ 198°C)	
Maximum backpressure for standard pumps (for higher backpressures contact Spirax Sarco)	72 psig (5 bar g)	
TMO Maximum operating temperature for saturated steam service	388°F @ 200 psig (198°C @ 13.8 bar g)	
Minimum operating temperature	14°F (-10°C)	
<b>Note:</b> For lower temperatures consult Spirax Sarco.		
Temperature limits (Ambient $\bar{x}$ )	14°F to 392°F (-10°C to 200°C)	
Designed for a maximum cold hydraulic test pressure of:	348 psig (24 bar g)	
Filling head	Recommended filling head above the pump (from the base of the receiver/process)	12 in (0.3 m)
	Maximum recommended filling head (from the base of the pump) for higher filling heads refer to Spirax Sarco	39 in (1 m)
	Minimum filling head required (from the base of the pump)	8 in (0.2 m)

## Nominal capacities

For full capacity details for a specific application consult Spirax Sarco. To accurately size the pump trap, the following data is required.

- Installation head available, from the base of the pump trap to the centre line of the heat exchanger / process condensate outlet (m). If the outlet is mounted vertically, then this should be from the base of the pump to the face of the outlet.
- Motive steam pressure available to power the pump trap (psig).
- Total backpressure in the condensate return system (psig). See note below.
- Heat exchanger full-load operating pressure (psig).
- Heat exchanger maximum steam load (lb/hr).
- Minimum temperature of secondary fluid. (°F).
- Maximum controlled temperature of secondary fluid (°F).

Model	APT14	APT14HC and APT14SHC
Pump discharge/cycle	1.3 gallons (5 litres)	2.1 gallons (8 litres)
Average Steam Consumption	13.2 lb/hr (6.0 kg/hr)	17.6 lb/hr (8.0 kg/hr)
39 inches installation head	Maximum trapping capacity 8800 lb/hr (4000 kg/h)	Maximum trapping capacity 19800 lb/hr (9000 kg/h)
At: 73 psig motive pressure		
15 psig total backpressure	Maximum pumping capacity 2420 lb/hr (1100 kg/h)	Maximum pumping capacity 6160 lb/hr (2800 kg/h)

**Note:** The capacities detailed within the above Table are only given as a guide. They are based on the installation parameters shown in the left hand column.

**Achieved capacities will differ if any of the installation parameters change.** For specific capacities and application details, contact Spirax Sarco.

The total lift or backpressure BP (static head plus pressure head in the return system) must be below the motive fluid inlet pressure to allow pump capacity to be achieved.

$$BP \text{ (backpressure)} = (H \times 2.31) + (P) + (Pf)$$

Height (H) in feet x 2.31 plus pressure (P) psig in the return line, plus downstream piping friction pressure drop (Pf) in psig.

(Pf can be ignored if the downstream pipework is less than 328 feet to a non-flooded condensate return and has been sized to take into account the effect of flash steam at the heat exchanger's full-load operating conditions.)

TI-5-228-US 4.17

# APT14 and APT14HC Automatic Pump Trap

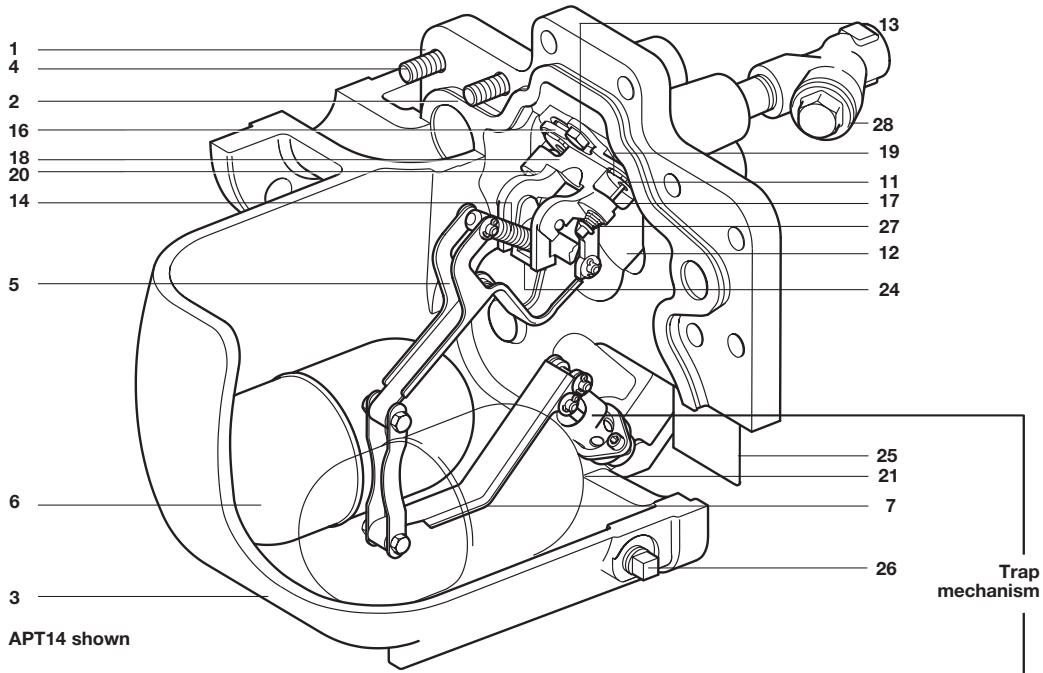

APT14 shown

## Materials

No.	Part	Material	
1	Cover	APT14	SG iron EN JS 1025 or ASTM A395
		APT14HC	SG iron EN JS 1025 or ASTM A395
		APT14SHC	Carbon steel EN 1.0619+N or ASTM A216 WCB
2	Cover gasket	Graphite laminated with stainless steel insert	
3	Body	APT14	SG iron EN JS 1025 or ASTM A395
		APT14HC	SG iron EN JS 1025 or ASTM A395
		APT14SHC	Carbon steel EN 1.0619+N or ASTM A216 WCB
4	Cover bolts	Stainless steel	ISO 3506 Gr. A2 70
	Location pins	APT14SHC only	Stainless steel 304
5	Pump lever	Stainless steel	BS 1449 304 S15
6	Float	Stainless steel	BS 1449 304 S15
7	Trap lever	Stainless steel	BS 1449 304 S15
8	Trap 2 <sup>nd</sup> stage valve	Stainless steel	ASTM A276 440 B
9	Trap housing	Stainless steel	BS 3146 ANC 2
10	Ball (APT14 only)	Stainless steel	ASTM A276 440 B
11	Seat (inlet check valve)	Stainless steel	AISI 420
12	Flap (inlet check valve)	Stainless steel	BS 3146 ANC 4B
13	Pump mechanism bracket	Stainless steel	BS 3146 ANC 4B
14	Spring (pump)	Stainless steel	BS 2056 302 S26 Gr. 2
15	Split pin	Stainless steel	BS 1574
16	Exhaust seat	Stainless steel	BS 970 431 S29 or ASTM A276 431
17	Inlet valve and seat assembly	Stainless steel	
18	Exhaust valve	Stainless steel	BS 3146 ANC 2
19	Valve seat gasket	Stainless steel	BS 1449 409 S19
20	Pump mechanism bolt	Stainless steel	ISO 3506 Gr. A2 70
21	Trap housing bolt	Stainless steel	BS 6105 A4 80
22	Trap 1 <sup>st</sup> stage valve	Stainless steel	BS 970 431 S29 or ASTM A276 431
23	'O' ring	EPDM	
24	Actuator arm	Stainless steel	BS 3146 ANC 2
25	Name-plate	Stainless steel	BS 1449 304 S16
26	Drain plug	Steel	DIN 17440 1.4571
27	Inlet valve spring	Stainless steel	
28	Motive strainer	APT14	SG iron
		APT14HC	SG iron
		APT14SHC	Carbon steel
29	DCV10 (APT14HC and APT14SHC)	Stainless steel (not shown)	

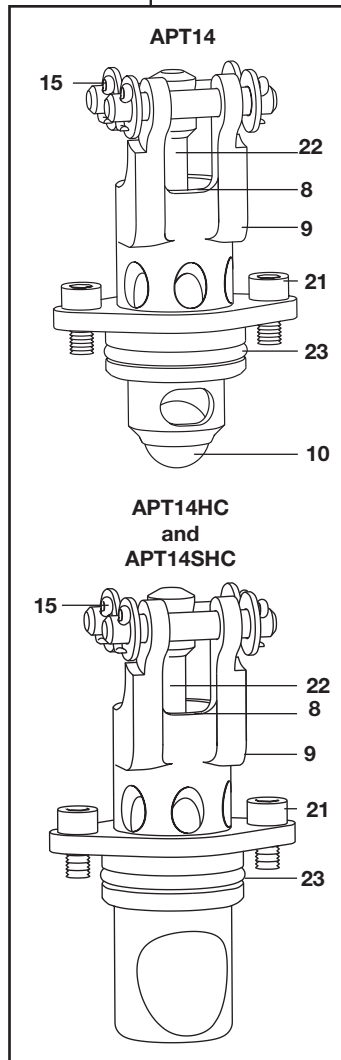

TI-5-228-US 4.17

# APT14 and APT14HC Automatic Pump Trap

## Safety information, installation and maintenance

For full details see the Installation and Maintenance Instructions (IM-P612-04) supplied with the product.

### How to specify

#### APT14 and APT14HC

The pump trap shall be a Spirax Sarco automatic pump trap type APT14 operated by steam to 200 psig. No electrical energy shall be required. Body construction from SG iron (EN JS 1025 dual certified with ASTM A395) with a swing type inlet check valve (APT14 and APT14HC) and ball type outlet check valve (APT14 only). The internal trap mechanism shall contain dual stainless steel floats connected with a two stage trap, while the internal pump mechanism shall be a stainless steel single tension spring snap-action device with no external seals or glands.

#### APT14SHC

The pump trap shall be a Spirax Sarco automatic pump trap type APT14SHC operated by steam to 200 psig. No electrical energy shall be required. Body construction from carbon steel (EN 1.0619 dual certified with ASTM A216 WCB) with a swing type inlet check valve. The internal trap mechanism shall contain dual stainless steel floats connected with a two stage trap, while the internal pump mechanism shall be a stainless steel single tension spring snap-action device with no external seals or glands.

### How to order

**Example:** 1 Spirax Sarco automatic pump trap, type APT14, 1½" x 1", ANSI 150 with NPT motive fluid connections.

#### Optional extras

Both the APT14 and APT14HC are available with the **body and cover coated with electroless nickel plate (ENP)**. This option, when required, will be denoted as **APT14 ENP and APT14HC ENP** respectively and must be stated at the time of order placement.

The APT14, APT14HC and APT14SHC are available with the body drilled, tapped and plugged to accept gauge glasses. **Note:** Gauge glasses can not be fitted retrospectively to the standard APT14, APT14HC or APT14SHC.

**Gauge glasses**, supplied separately, are available for the APT14, APT14HC or APT14SHC. For further details contact Spirax Sarco.

### Spare parts

The spare parts available are shown in solid outline. Parts drawn in broken line are not supplied as spares.

#### Available spares

<b>A</b>	Cover assembly (A - G inclusive)	1, 2, 5-25
<b>B</b>	Cover gasket	2
<b>C</b>	Inlet check valve	2, 12
<b>D</b>	Spring and actuator arm	2, 14, 24
<b>E</b>	Floats	2, 5, 6, 7
<b>F</b>	Trap and outlet check valve mechanism	2, 8, 9, 10 (APT14 only), 21, 22, 23
<b>G</b>	Inlet/exhaust valve and seat kit	2, 16, 17, 18, 19, 27
<b>H</b>	See separate literature: For the <b>APT14</b> or <b>APT14HC</b> see TI-P163-01 and for the <b>APT14SHC</b> see TI-P063-02	28

**DCV10 outlet check valve** (APT14HC and APT14SHC only). See separate literature TI-P601-32 **29**

**Please note:** For customer convenience, spares are supplied in kits to ensure all the appropriate replacement parts are available e.g. when an inlet/exhaust valve and seat assembly is ordered, all replacement split pins, washers and gaskets will be provided in addition to the key components listed.

#### How to order spares

Always order spares by using the description given in the column headed 'Available spares' and state the size and type of unit.

**Example:** 1 - Inlet/exhaust valve and seat kit for a Spirax Sarco 1½" x 1" APT14 automatic pump trap.

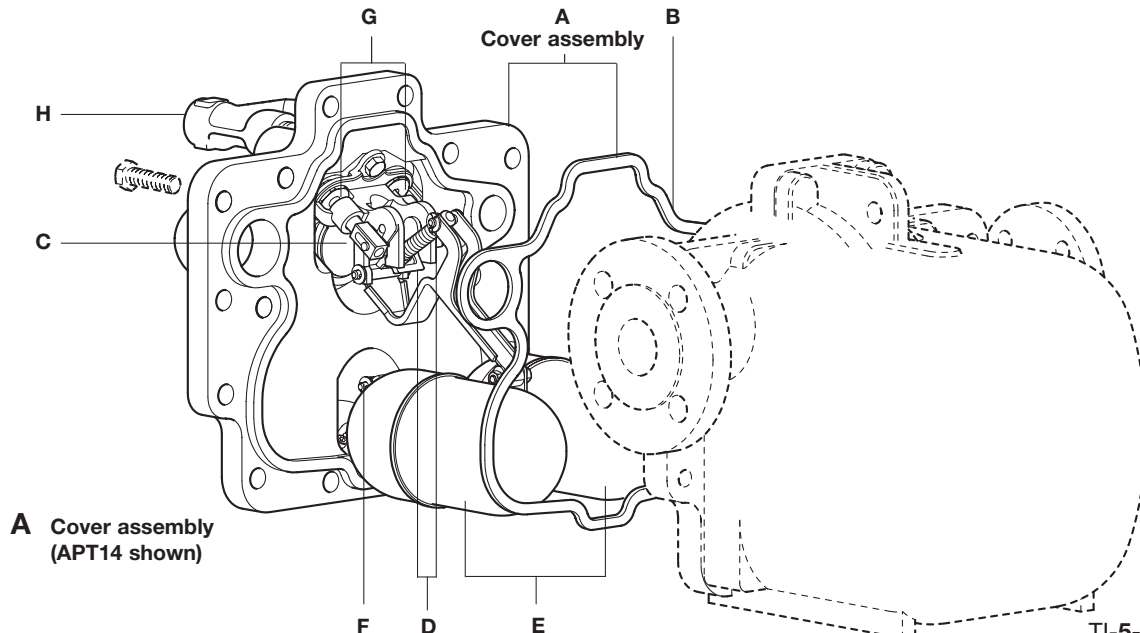

**A** Cover assembly (APT14 shown)

TI-5-228-US 4.17

# APT14 and APT14HC Automatic Pump Trap

**B Cover gasket**

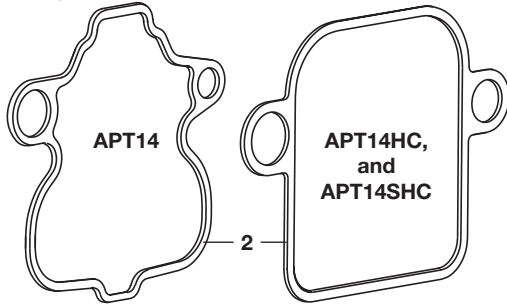

**C Inlet check valve**

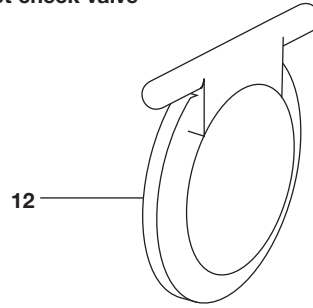

**D Spring and actuator arm**

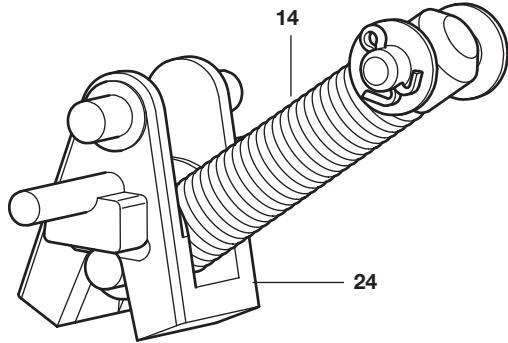

**E Floats**

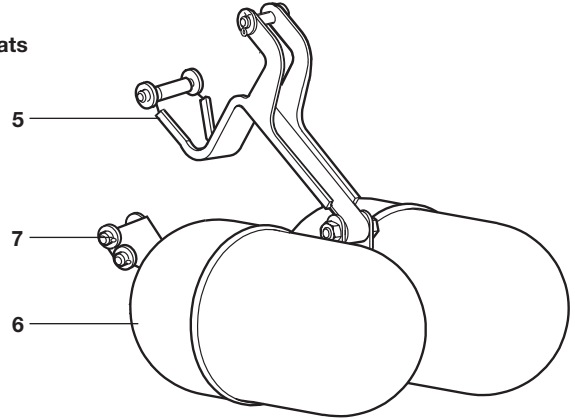

**F Trap and outlet check valve mechanism**

Note: Item 10 is not included for the APT14HC and APT14SHC

**APT14**

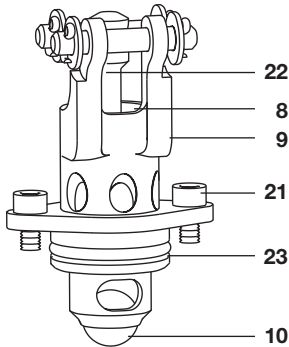

**APT14HC and APT14SHC**

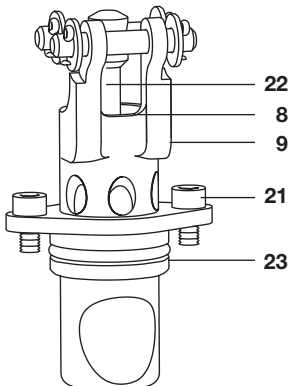

**G Inlet / exhaust valve and seat kit**

**APT14**

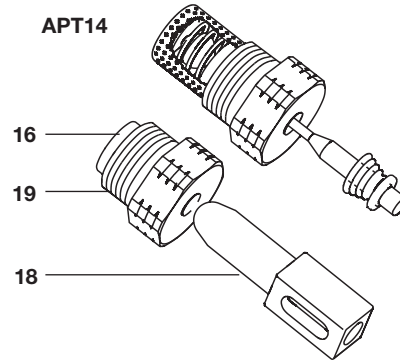

**APT14HC and APT14SHC**

